

## Design

The Hallite 834 wiper is designed to snap into a standard housing and provide reliable medium duty dirt exclusion. The proportions of the wiping lip ensure that it remains in contact with the rod surface to remove all deposits of mud and other forms of contamination except for those found in the heavy duty environment such as steel works and cement factories.

The inside diameter of the seal is provided with ribs to prevent the possibility of blow out due to pressure trapping of the main rod seal.

The Hallite® 834 is precision moulded in Hythane® 181 for maximum wear resistance.

Part numbers suffixed by † indicate housing sizes to meet ISO 6195E.

### Features

- Snug fit provides effective sealing
- Long life
- Low wear
- Easy installation
- Pressure relief ribs

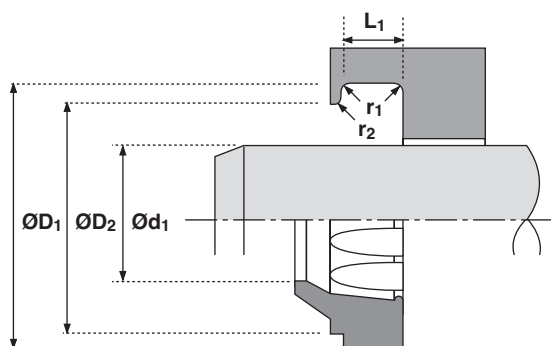

### Technical details

#### Operating conditions

Maximum Speed 4.0 m/sec  
Temperature Range -45°C +110°C

#### Inch

12.0 ft/sec  
-50°F +230°F

#### Surface roughness

	µmRa	µmRt
Dynamic Sealing Face Ød <sub>1</sub>	0.1 <> 0.4	4 max
Static Sealing Face ØD <sub>1</sub> ØD <sub>2</sub>	1.6 max	10 max
Static Housing Faces L <sub>1</sub>	3.2 max	16 max

µinCLA	µinRMS
4 <> 16	5 <> 18
63 max	70 max
125 max	140 max

#### Radii

Max Fillet Rad r <sub>1</sub> mm	0.4
Max Fillet Rad r <sub>2</sub> mm	0.2

#### Tolerances

mm	Ød <sub>1</sub>	ØD <sub>1</sub>	ØD <sub>2</sub>	L <sub>1</sub>
	f9	H11	H11	+0.2 -0

