

## Design

The Hallite 764 is a compact seal for light to medium duty hydraulic cylinders. It is a double acting piston seal with single acting capabilities. This makes it an excellent choice for double acting applications where minimal dynamic leakage is required.

The Hallite 764 comprises of a tough elastomeric face that is pre-loaded by an O ring. The housing width allows a narrow width piston to be used, but it is recommended that an adequate bearing is mounted on one or both sides of the seal.

Housing dimensions for use with Hallite 87 and 506 bearing strip are given in the installation details. For further details on bearing strip grooves, please refer to the appropriate data sheets.

**NB:** Part numbers suffixed by “+” indicate housing sizes to meet ISO 7425-1.

For full details and availability please contact your local Hallite Sales office.

## Features

- Double acting seal with single acting capabilities
- Excellent wear resistance
- High extrusion resistance ideal for use with Hallite 506 or 87
- More tolerant to dirt and contamination than common PTFE faces
- Rapid recovery after assembly
- Advanced face geometry provides enhanced dynamic and static sealing
- ISO 7425 housing

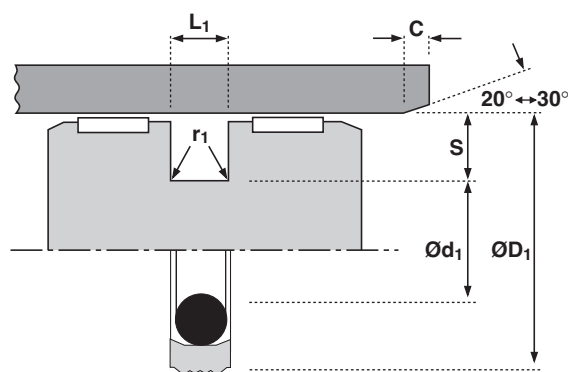

## Technical details

### Operating conditions

Maximum Speed	1.0 m/sec
Temperature Range	-30°C + 110°C
Maximum Pressure	250 bar

### Inch

3.0 ft/sec
-22°F + 230°F
3600 p.s.i.

### Maximum extrusion gap

Pressure bar	100	160	250
Maximum Gap mm	0.6	0.5	0.4

Figures show the maximum permissible gap all on one side using minimum rod  $\varnothing$  and maximum clearance  $\varnothing$ . Refer to Housing Design section

### Surface roughness

	$\mu\text{mRa}$	$\mu\text{mRt}$	$\mu\text{inCLA}$	$\mu\text{inRMS}$
Dynamic Sealing Face $\varnothing D_1$	0.1 < > 0.4	4 max	4 < > 16	5 < > 18
Static Sealing Face $\varnothing d_1$	1.6 max	10 max	63 max	70 max
Static Housing Faces $L_1$	3.2 max	16 max	125 max	140 max

### Chamfers & Radii

	mm	mm	mm	mm
Groove Section $\leq S$	3.75	5.50	7.75	10.50
Min Chamfer C	2.0	2.5	5.0	5.0
Max Fillet Rad $r_1$	0.4	0.8	1.2	1.6
Groove Section $\leq S$ in	0.150	0.220	0.310	0.410
Min Chamfer C in	0.080	0.100	0.200	0.200
Max Fillet Rad $r_1$ in	0.016	0.032	0.047	0.063

### Tolerances

$\varnothing D_1$	$\varnothing d_1$	$L_1$ mm	$L_1$ in
H9	h9	+0.2 -0	+0.008-0

