

Design

The Hallite 13 is a Vee pack rod seal for heavy duty applications offering excellent performance and long life even under difficult operating conditions such as pressure surges, vibration and some misalignment. The seal assembly consists a male and female adaptor and 5 vee rings.

The male adaptor is usually manufactured from polyacetal but some of the larger sizes use rubberised fabric. It has grooves across one face to ensure equal pressure to the sealing edges of the vee ring.

All sizes have vee rings manufactured from rubberised fabric because this has strength and durability and permits an oil film to lubricate the other parts of the seal. Some sizes are supplied with rubber vee rings between the rubberised fabric vee rings. The number and type of vee rings used are:

	up to 89mmØ	90-139mmØ	Above 139mmØ
Ruberised Fabric Vee Rings	3	4	5
Rubber Vee Rings	2	1	

The female adaptor uses a hard rubberised fabric to support the vee rings and protect them from extrusion damage. At high pressures the lips of the adaptor act as a secondary seal.

Features

- Precision moulded vee rings
- Pressure distribution adaptors
- Reliable sealing

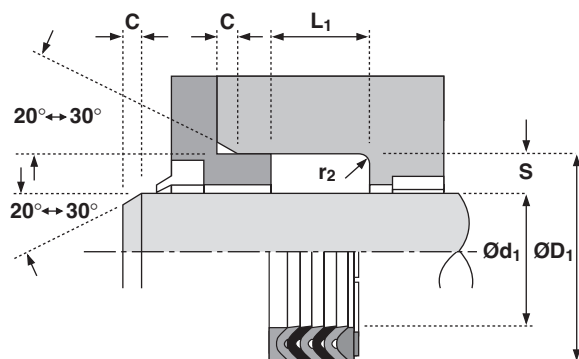

Technical details

Operating conditions

Maximum Speed
Temperature Range
Maximum Pressure

Metric

0.5 m/sec
-30°C + 100°C
700 bar

Inch

1.5 ft/sec
-22°F + 212°F
10,000 p.s.i.

Maximum extrusion gap

Figures show the maximum permissible gap all on one side using minimum rod \varnothing and maximum clearance \varnothing . Refer to Housing Design section.

	160	250	400	700
Pressure bar	160	250	400	700
Maximum Gap mm	0.4	0.3	0.2	0.1
Pressure p.s.i.	2400	3750	6000	10,000

Surface roughness

Dynamic Sealing Face $\varnothing d_1$
Static Sealing Face $\varnothing D_1$
Static Housing Faces L_1

	μmRa	μmRt	μinCLA	μinRMS
Dynamic Sealing Face $\varnothing d_1$	0.1 < > 0.4	4 max	4 < > 16	5 < > 18
Static Sealing Face $\varnothing D_1$	1.6 max	10 max	63 max	70 max
Static Housing Faces L_1	3.2 max	16 max	125 max	140 max

Chamfers & Radii

Groove Section $\leq S$ mm
Min Chamfer C mm
Max Fillet Rad r_1 mm

	6.0	7.5	10.0	12.5	15.0	20.0
Groove Section $\leq S$ mm	6.0	7.5	10.0	12.5	15.0	20.0
Min Chamfer C mm	3.0	4.0	5.0	6.5	7.5	10.0
Max Fillet Rad r_1 mm	0.4	0.4	1.2	1.6	1.6	1.6

Tolerances

	$\varnothing d_1$	$\varnothing D_1$	L_1 mm
	f9	H11	+0.2 -0

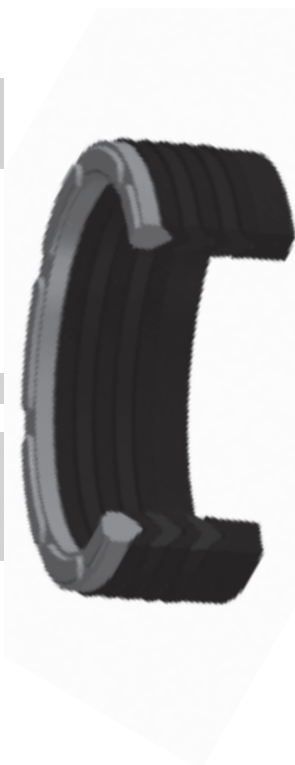

vee pack sets