

Design

Hallite 09 vee packings incorporate the Hallite 08 vee ring manufactured from fabric reinforced high grade nitrile rubber, which is normally used in multiples in a set with a male and female adaptor. The parts are 'stacked' together and must be lubricated liberally with clean operating fluid prior to assembly.

The packing must be axially pre-loaded by the housing. This preload works through the male adaptor on the pressure side, exerting a hinging action on the vees, forcing the sealing lips apart to ensure a low pressure seal. As the pressure increases, so the hinging action increases, increasing the effectiveness of the seal even where severe vibration, shock loading and knuckling may occur.

The standard Hallite 09 comprises of three vees and two adaptors, available in metric and imperial inch sizes. In addition to the ranges the Hallite 09 is also available for standard American inch housings. Some adaptors are rubber fabric while others are polyacetal resin. Individual vee rings are stocked to supplement the sets, but it should be noted that individual adaptors are only available in special circumstances.

For sizes not listed or for special requirements, please contact your Hallite sales office.

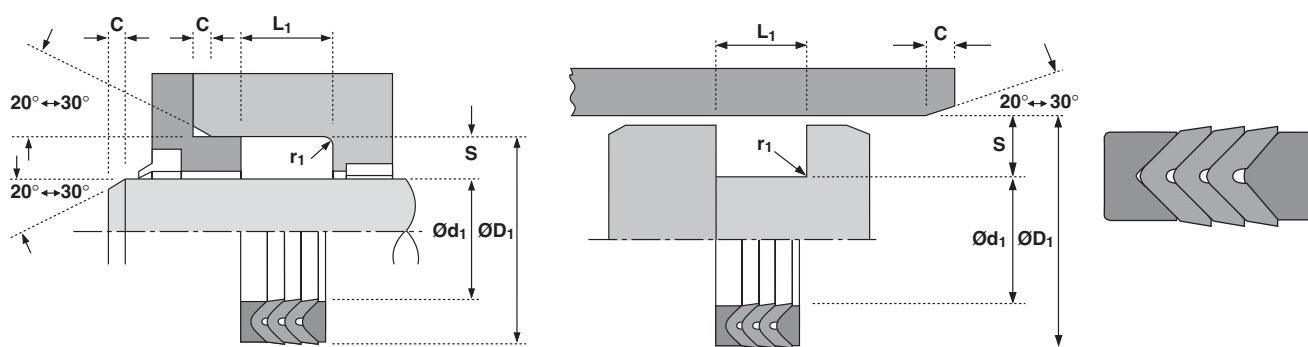

Technical details

Operating conditions

Maximum Speed

Temperature Range

Maximum Pressure

Metric

0.5 m/sec

-30°C +100°C

400 bar

Inch

1.5 ft/sec

-22°F +212°F

6000 p.s.i.

Maximum extrusion gap

Figures show the maximum permissible gap all on one side, for rod seals using minimum rod \varnothing and maximum clearance \varnothing and for piston seals using the minimum clearance \varnothing and maximum bore \varnothing . Refer to Housing Design section.

Pressure bar

Maximum Gap mm

Pressure p.s.i.

Maximum Gap in

Pressure bar	100	175	250	400
Maximum Gap mm	0.45	0.4	0.3	0.2
Pressure p.s.i.	1500	2250	3500	6000
Maximum Gap in	0.018	0.015	0.010	0.007

Surface roughness

Dynamic Sealing Face – Rod $\varnothing d_1$

Static Sealing Face – Rod $\varnothing D_1$

Dynamic Sealing Face – Piston $\varnothing d_1$

Static Sealing Face – Piston $\varnothing D_1$

Static Housing Faces L_1

	μmRa	μmRt	μinCLA	μinRMS
Dynamic Sealing Face – Rod $\varnothing d_1$	0.1 < > 0.4	4 max	4 < > 16	5 < > 18
Static Sealing Face – Rod $\varnothing D_1$	1.6 max	10 max	63 max	70 max
Dynamic Sealing Face – Piston $\varnothing d_1$	0.1 < > 0.4	4 max	4 < > 16	5 < > 18
Static Sealing Face – Piston $\varnothing D_1$	1.6 max	10 max	63 max	70 max
Static Housing Faces L_1	3.2 max	16 max	125 max	140 max

Chamfers & Radii

Groove Section $\leq S$ mm

Min Chamfer C mm

Max Fillet Rad r_1 mm

Groove Section $\leq S$ in

Min Chamfer C in

Max Fillet Rad r_1 in

	5.0	7.5	10.0	12.5	15.0
Min Chamfer C mm	3.0	5.0	6.5	7.0	7.5
Max Fillet Rad r_1 mm	0.5	0.8	0.8	0.8	0.8
Groove Section $\leq S$ in	0.187	0.250	0.312	0.375	0.500
Min Chamfer C in	0.093	0.125	0.156	0.187	0.250
Max Fillet Rad r_1 in	0.020	0.031	0.031	0.031	0.031

Tolerances

Rod

Piston

	$\varnothing d_1$	$\varnothing D_1$	L_1 mm	L_1 in
Rod	f9	Js11	+0.75 -0.0	+0.030 -0
Piston	js11	H9	+0.75 -0.0	+0.030 -0



vee pack sets