

## Options Saturn, groupe 3

### AXE CONIQUE 1:8 (EUR) 10

BRIDE AVANT				
E				

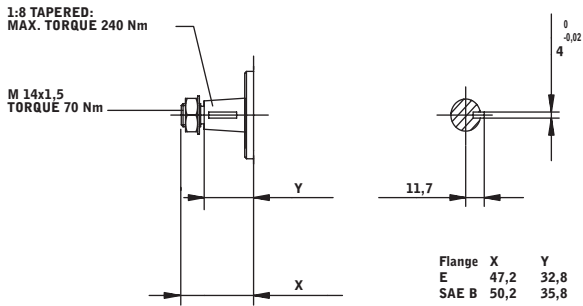

### AXE DROIT 13

BRIDE AVANT				
E	SAE B			

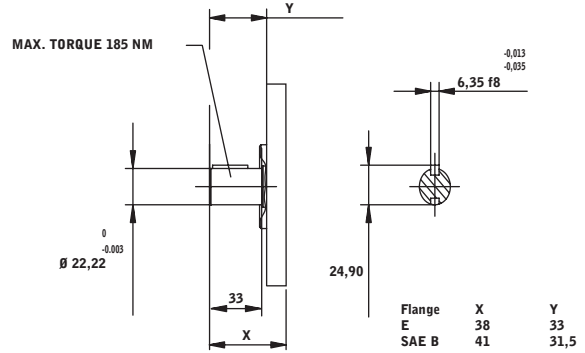

### SAE "B" AXE CANNÉLÉ 14

BRIDE AVANT				
E	SAE B			

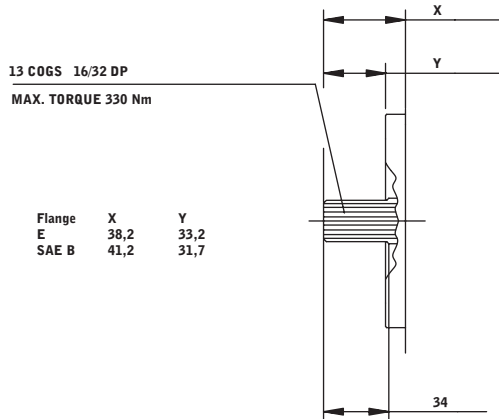

### SAE "B" (2 TROUS) B

### BRIDE RECTANGULAIRE (EUR) E

