

SPLINE Z9 16/32  
30° ANSI B92.1  
FLAT ROOT SIDE FIT

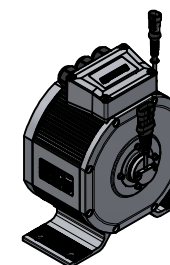

Scala 1 / 8

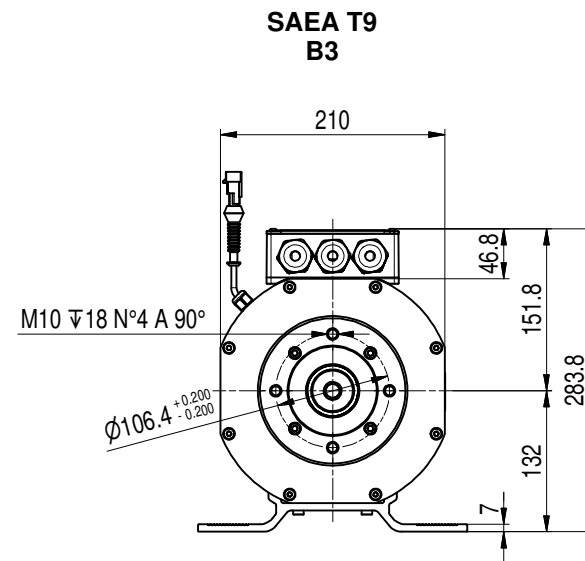
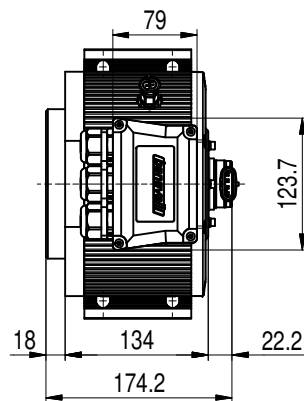

DATASHEET MOTORE	MOTOR DATASHEET		
MOTORE	MOTOR		
POTENZA	POWER	W	
TENSIONE BATTERIA	BATTERY VOLTAGE	Vdc	
TENSIONE FASE	VOLTAGE ON PHASE	Vac	
GIRI NOMINALI	RATED SPEED	rpm	
GIRI MASSIMI	MAX SPEED	rpm	
COPPIA MAX	MAX TORQUE	Nm	
CORRENTE NOMINALE	RATED CURRENT	A	
FREQUENZA NOMINALE	RATED FREQUENCY	Hz	
SERVIZIO	DUTY	S2	
PROTEZIONE	PROTECTION	IP	
CLASSE ISOLAMENTO	INSULATION CLASS	INS	
IMPULSI ENCODER	PULSES REVOLUTION	N°	
FRENO EM	EM BRAKE	Nm - V	
PESO	WEIGHT	kg	

N°	Descrizione modifica	Data	Dis.	Pos.

disegnato / drawn <b>mc</b>	data / date 22/1/2021	<b>INGOMBRO / DIMENSION</b>		<b>benevelli</b> Rubiera-Reggio Emilia-Italy www.benevelli.it	
controllato / checked	data / date				
scala / scale 1:5(1:8)	formato foglio / sheet size A3	descrizione / name		gruppo/group	sottogruppo/subgroup
revisione / reference 00	n° foglio / sheet no 1 / 1			n° disegno/drawing no	