

Technical Information

PLUS+1[®] Mobile Machine Displays

DM1x00 Series



Revision history

Table of revisions

Date	Changed	Rev
August 2019	First edition	0101

Contents

DM1x00 literature references

Technical Information (TI).....	4
Data Sheet (DS).....	4
PLUS+1® GUIDE User Manual.....	4
Latest version of technical literature.....	4

User liability and safety statements

OEM responsibility.....	5
Safety statements.....	5
Display operation guidelines.....	5
Machine wiring guidelines.....	6
Machine welding guidelines.....	6

Overview

DM1x00 Series Displays description.....	7
Features.....	7
PLUS+1® GUIDE.....	7
LCD features.....	8

Ordering information

Model variants.....	9
Model code.....	9
Model code key.....	9
Related products.....	10

Input/output types and specifications

Input types.....	11
Digital/analog.....	11
Multifunction inputs.....	12
CAN shield and analog input.....	14
Digital output.....	14
CAN communication.....	15
USB communication.....	15
RS232 communication.....	15
Sensor output.....	15
Video power.....	15
Ethernet.....	16

Product ratings

DM1x00 environmental testing criteria.....	17
Supply voltage/maximum current ratings.....	17
Ingress Protection (IP) rating	18

Installation

DM1x00 Series Displays dimensions.....	19
Button options.....	19
Pin assignments C1—C9.....	20
Standard Mount.....	22
Mounting panels cutouts.....	23
RAM mount.....	23
Fastening.....	24
Visibility and viewing radius.....	25
Display faulty application recovery.....	25
Cleaning.....	25

DM1x00 literature references

Reference literature

Literature title	Literature type	Literature number
<i>DM1x00 Series PLUS+1° Mobile Machine Displays</i>	Technical Information	BC313277849405
<i>DM1x00 Series PLUS+1° Mobile Machine Displays</i>	Data Sheet	AI304864913574
<i>PLUS+1° GUIDE Software</i>	User Manual	AQ00000026

Technical Information (TI)

A TI is comprehensive information for engineering and service personnel to reference.

Data Sheet (DS)

A DS is summarized information and parameters that are unique to a specific model.

PLUS+1° GUIDE User Manual

The Operation Manual (OM) details information regarding the PLUS+1° GUIDE tool used in building PLUS+1° applications. This OM covers the following broad topics:

- How to use the PLUS+1° GUIDE graphical application development tool to create machine applications
- How to configure module input and output parameters
- How to download PLUS+1° GUIDE applications to target PLUS+1° hardware modules
- How to upload and download tuning parameters
- How to use the PLUS+1° Service Tool

Latest version of technical literature

Comprehensive technical literature is online at www.danfoss.com

User liability and safety statements

OEM responsibility

The OEM of a machine or vehicle in which Danfoss products are installed has the full responsibility for all consequences that might occur. Danfoss has no responsibility for any consequences, direct or indirect, caused by failures or malfunctions.

- Danfoss has no responsibility for any accidents caused by incorrectly mounted or maintained equipment.
- Danfoss does not assume any responsibility for Danfoss products being incorrectly applied or the system being programmed in a manner that jeopardizes safety.
- All safety critical systems shall include an emergency stop to switch off the main supply voltage for the outputs of the electronic control system. All safety critical components shall be installed in such a way that the main supply voltage can be switched off at any time. The emergency stop must be easily accessible to the operator.

Safety statements

Display operation guidelines

- Disconnect your machine's battery power before connecting power and signal cables to the display.
- Before doing any electrical welding on your machine, disconnect all power and signal cables connected to the display.
- Do not exceed the display power supply voltage ratings. Using higher voltages may damage the display and can create a fire or electrical shock hazard.
- Do not use or store the display where flammable gases or chemicals are present. Using or storing the display where flammable gases or chemicals are present may cause an explosion.
- Software configures the keypad buttons on the display. Do not use these buttons to implement critical safety features. Use separate mechanical switches to implement critical safety features such as emergency stops.
- Design systems that use the display so that a communication error or failure between the display and other units cannot cause a malfunction that might injure people or damage material.
- The protective glass over the display screen will break if hit with a hard or heavy object. Install the display to reduce the possibility of it being hit by hard or heavy objects.
- Storing or operating a display in an environment that exceeds the display specified temperature or humidity rating may damage the display.
- Always clean the display with a soft, damp cloth. Use a mild dishwashing detergent as needed. To avoid scratching and discoloring the display, do not use abrasive pads, scouring powders, or solvents such as alcohol, benzene, or paint thinner.
- Keep ambient light sensor area clean and uncovered for best operation.
- Danfoss graphical displays are not user serviceable. Return the display to the factory in case of failure.

User liability and safety statements

Machine wiring guidelines

Warning

Unintended movement of the machine or mechanism may cause injury to the technician or bystanders. Improperly protected power input lines against over current conditions may cause damage to the hardware. Properly protect all power input lines against over-current conditions. To protect against unintended movement, secure the machine.

Caution

Unused pins on mating connectors may cause intermittent product performance or premature failure. Plug all pins on mating connectors.

- Protect wires from mechanical abuse, run wires in flexible metal or plastic conduits.
- Use 85° C (185° F) wire with abrasion resistant insulation and 105° C (221° F) wire should be considered near hot surfaces.
- Use a wire size that is appropriate for the module connector.
- Separate high current wires such as solenoids, lights, alternators or fuel pumps from sensor and other noise-sensitive input wires.
- Run wires along the inside of, or close to, metal machine surfaces where possible, this simulates a shield which will minimize the effects of EMI/RFI radiation.
- Do not run wires near sharp metal corners, consider running wires through a grommet when rounding a corner.
- Do not run wires near hot machine members.
- Provide strain relief for all wires.
- Avoid running wires near moving or vibrating components.
- Avoid long, unsupported wire spans.
- Ground electronic modules to a dedicated conductor of sufficient size that is connected to the battery (-).
- Power the sensors and valve drive circuits by their dedicated wired power sources and ground returns.
- Twist sensor lines about one turn every 10 cm (4 in).
- Use wire harness anchors that will allow wires to float with respect to the machine rather than rigid anchors.

Machine welding guidelines

Warning

High voltage from power and signal cables may cause fire or electrical shock, and cause an explosion if flammable gasses or chemicals are present.

Disconnect all power and signal cables connected to the electronic component before performing any electrical welding on a machine.

The following is recommended when welding on a machine equipped with electronic components:

- Turn the engine off.
- Remove electronic components from the machine before any arc welding.
- Disconnect the negative battery cable from the battery.
- Do not use electrical components to ground the welder.
- Clamp the ground cable for the welder to the component that will be welded as close as possible to the weld.

Overview

DM1x00 Series Displays description

The Danfoss DM1x00 display series bring modern appearance and performance to mobile machine markets with two display platforms, expanding the PLUS+1® family.

The DM1x00 series was developed for best operator viewability with its high brightness, optical bonding, anti-glare, anti-reflection, oleophobic coating and wide viewing angles. It is quipped with an outstanding dual core 1.2 GHz i.MX6 and 4Gb flash memory delivering high performance. Ruggedized for mobile machine markets, it is built to withstand harsh operating environments with its IP66 and IP67 rating and the water-resistant screen allowing for multi-touch while wearing gloves.

The integrated file viewer and media player provides view of documents and media files on the run using the audio line out to connect to the vehicle speaker system.

To meet specific needs, the DM1x00 includes two different screen sizes (10.1" and 12.1") with optional multi-touch and two button pad configurations with programmable back-lights and tactile feedback.

WiFi and Bluetooth® provide wireless channels for servicing the machine remotely.

Features

- 4 CAN ports
- RS232 and USB 2.0 high-speed
- Ethernet
- Bluetooth® and WiFi, GNSS (optional)
- 4 Camera inputs (Up to 2 displayed at one time)
- Audio line out
- Sensor supply out
- Optional keypad with either 8 buttons on each side (16 total) or 8 buttons plus navigation panel (16 total)
- Backlit buttons
- Touch screen (optional)
- Optical signal (2 RGB LEDs)
- Integrated ambient light sensor for automatically adjusting brightness to lighting conditions
- Ignition input
- Wake up over input
- Dual core 1.2 GHz i.MX6
 - 4 GB Flash memory
- Media player and File viewer (PDF, JPG, MP3, MP4)
- PLUS+1® GUIDE programmable
- Real Time Clock (RTC)
- Rugged IP66 and IP67 rating
- 2 Integrated DEUTSCH connectors
- CE Compliant, E1 E-Mark and RoHS Compliant
- FCC certification for displays with radio
- Fast Start-up Time (less than 5 seconds)
- RAM® or Bracket (optional) mount (portrait or landscape)
- Integrated accelerometer for auto-adjusting between screen orientations
- 32 MB App Log

PLUS+1® GUIDE

PLUS+1® GUIDE (Graphical User Integrated Development Environment) is a complete toolbox that generates downloadable applications for all programmable PLUS+1® Compliant products.

Overview

A screen editor allows easy development of applications by programmers without formal software development training. The expertise from a software engineer is not needed to find your way around in PLUS+1® GUIDE.

! Caution

Unwanted system failure may occur.

Refer to PLUS+1® GUIDE Software User Manual, **AQ00000026** for best programming practices.

<https://www.danfoss.com/en/products/software/dps/plus1-software/plus1-guide/#tab-overview>

LCD features

DM1000 LCD 10.1" screen

Description	Values			Unit	Notes
	Min.	Typ.	Max.		
Screen Size		10.1		Inch	
Resolution		1280 x 800		Pixels	
Luminance	700	800		cd/m2	
Contrast Ratio		500:01:00			
Viewing Angle		± 85		Degree	Top, bottom, left, right
Color Depth		24		Bits	8 bits per color

DM1200 LCD 12.1" screen

Description.	Values.			Unit.	Notes.
	Min.	Typ.	Max.		
Screen Size		12.1		Inch	
Resolution		1280 x 800		Pixels	
Luminance	700	800		cd/m2	
Contrast Ratio		500:01:00			
Viewing Angle		± 85		Degree	Top, bottom, left, right
Color Depth		24		Bits	8 bits per color

Ordering information

Model variants

Part number	Order code	Description
11223953	DM1000-0-0-0-0	10.1", Non-Touch, No Buttons
11223954	DM1000-0-1-0-0	10.1", Non-Touch, No Buttons, WIFI/BT/GNSS
11223955	DM1000T-0-0-0-0	10.1", Touch, No Buttons
11223957	DM1000T-0-1-0-0	10.1", Touch, No Buttons, WIFI/BT/GNSS
11223958	DM1000-0-0-1-0	10.1", Non-Touch, 2x8 Buttons
11223956	DM1000-0-0-2-0	10.1", Non-Touch, 1x8 + Navigation Buttons
11223959	DM1000-0-1-1-0	10.1", Non-Touch, 2x8 Buttons, WIFI/BT/GNSS
11223960	DM1000-0-1-2-0	10.1", Non-Touch, 1x8 + Navigation Buttons, WIFI/BT/GNSS
11223961	DM1000T-0-0-1-0	10.1", Touch, 2x8 Buttons
11223965	DM1000T-0-0-2-0	10.1", Touch, 1x8 + Navigation Buttons
11223962	DM1000T-0-1-1-0	10.1", Touch, 2x8 Buttons, WIFI/BT/GNSS
11223966	DM1000T-0-1-2-0	10.1", Touch, 1x8 + Navigation Buttons, WIFI/BT/GNSS
11223963	DM1200T-0-0-0-0	12.1", Touch, No Buttons
11223964	DM1200T-0-1-0-0	12.1", Touch, No Buttons, WIFI/BT/GNSS

[Mounting kits are sold separately.](#)

Model code

A	B	C	D	E
DM1x00				

Model code key

A—Model name	Description
DM1000	10.1" Non-Touch
DM1000T	10.1" Touch
DM1200T	12.1" Touch

B—Not configured	Description
0	NC

C—WIFI/BT/GNSS	Description
0	Without WIFI/BT/GNSS
1	With WIFI/BT/GNSS

D—Buttons	Description
0	No Buttons
1	2x8 Buttons
2	1x8 + Navigation Buttons

E—Not configured	Description
0	NC

Ordering information

Related products

Connector kit

10100944	DEUTSCH 12-pin Connector Kit (DTM06-12SA)
-----------------	---

Cable kits

11231512	Cable, M12 8-Pin to USB Device
11130713	Cable, M12 8-Pin to Lead Wires

Panel mounting kits (sold separately)

11224242	Panel mounting kit for 10" Display unit with no buttons
11224243	Panel mounting kit for 10" Display unit with buttons
11224244	Panel mounting kit for 12" Display unit

Software

11179523 (annual renewal with 11179524 to keep the software updates)	PLUS+1® GUIDE Professional Software (includes 1 year of software updates, a single user license, Service and Diagnostic Tool and Screen Editor)
---	---

Connection tools

10100744	DEUTSCH stamped contacts terminal crimp tool, size 20
10100745	DEUTSCH solid contacts terminal crimp tool

Input/output types and specifications

Input types

DM1x00 Series displays support the following pin types:

- Digital or Analog (DIN/AIN)
- Multifunction (Din/AIN/FreqIN, Rheo, 4–20 mA)
- Fixed Range Analog or CAN shield (AIN/CAN shield)

Each PLUS+1® Module input pin supports one of the above functional types. For pins with multiple functions, input configurations are user programmable using PLUS+1® GUIDE templates.

When using inputs in digital mode, it is advised to use the software selectable pull-up or pull-down resistors.

Digital/analog

Middle range

Description	Unit	Minimum	Typical	Maximum	Comment
Minimum discernible voltage	V	—	—	0.03	—
Minimum discernible voltage	V	5.69	5.78	5.88	—
Resolution	mV	—	1.4	—	—
Worst case offset and gain error	V	—	—	±0.14	$V_{\text{Measure}} = 5.78 \text{ V}$
Non-linearity	mV	—	—	±8.5	—
Input impedance	kΩ	232	233	234	No pull up or pull down
Input impedance (5V/GND)	kΩ	13.9	14.1	14.3	Pull up or pull down
Input impedance (2.5V)	kΩ	7.1	7.3	7.4	Pull up and pull down

High range

Description	Unit	Minimum	Typical	Maximum	Comment
Minimum discernible voltage	V	—	—	0.16	—
Maximum discernible voltage	V	37.9	38.8	39.7	—
Resolution	mV	—	9.5	—	—
Worst case offset and gain error	V	—	—	0.95	$V_{\text{Measure}} = 38.8 \text{ V}$
Non-linearity	mV	—	—	±56.8	—
Input impedance	kΩ	109.1	109.3	109.5	No pull up or pull down ($V_{\text{in}} < 5.7 \text{ V}$)
Input impedance (5V/GND)	kΩ	13.0	13.2	13.4	Pull up or pull down ($V_{\text{in}} < 5.7 \text{ V}$)
Pull up and pull down input impedance (2.5V)	kΩ	6.9	7.0	7.1	Pull up and pull down ($V_{\text{in}} < 5.7 \text{ V}$)

Input/output types and specifications

Multifunction inputs

Low range analog

Description	Unit	Minimum	Typical	Maximum	Comment
Minimum discernible voltage	mV	—	—	13	—
Maximum discernible voltage	mV	379	404	430	—
Resolution	mV	—	0.1	—	—
Worst case offset and gain error	mV	—	—	±0.6	$V_{\text{Measure}} = 404 \text{ mV}$
Non-linearity	mV	—	—	±26	—
Input impedance	k Ω	232	233	234	No pull up or pull down
Input impedance (5V/GND)	k Ω	13.9	14.1	14.3	Pull up or pull down
Input impedance (2.5V)	k Ω	7.1	7.3	7.4	Pull up and pull down

Middle range analog

Description	Unit	Minimum	Typical	Maximum	Comment
Minimum discernible voltage	V	—	—	0.03	—
Maximum discernible voltage	V	5.69	5.78	5.88	—
Resolution	mV	—	1.4	—	—
Worst case offset and gain error	V	—	—	±0.14	$V_{\text{Measure}} = 5.78 \text{ V}$
Non-linearity	mV	—	—	±8.5	—
Input impedance	k Ω	232	233	234	No pull up or pull down
Input impedance (5V/GND)	k Ω	13.9	14.1	14.3	Pull up or pull down
Input impedance (2.5V)	k Ω	7.1	7.3	7.4	Pull up and pull down

High range analog

Description	Unit	Minimum	Typical	Maximum	Comment
Minimum discernible voltage	V	—	—	0.16	—
Maximum discernible voltage	V	37.9	38.8	39.7	—
Resolution	mV	—	9.5	—	—
Worst case offset and gain error	V	—	—	±0.95	$V_{\text{Measure}} = 38.8 \text{ V}$
Non-linearity	mV	—	—	±56.8	—

Input/output types and specifications

High range analog (continued)

Description	Unit	Minimum	Typical	Maximum	Comment
Input impedance	k Ω	109.1	109.3	109.5	No pull up or pull down ($V_{in} < 5.7$ V)
Input impedance (5V/GND)	k Ω	13.0	13.2	13.4	Pull up or pull down ($V_{in} < 5.7$ V)
Input impedance (2.5V)	k Ω	6.9	7.0	7.1	Pull up and pull down ($V_{in} < 5.7$ V)

Low range frequency (PPU)

Description	Unit	Minimum	Typical	Maximum	Comment
Range	Hz	0	—	10000	In steps of 1 Hz
Rising voltage threshold	mV	—	—	314	
Falling voltage threshold	mV	55	—	—	
Input impedance	k Ω	232	233	234	No pull up or pull down
Input impedance (5V/GND)	k Ω	13.9	14.1	14.3	Pull up or pull down
Input impedance (2.5V)	k Ω	7.1	7.3	7.4	Pull up and pull down

Middle range frequency (PPU)

Description	Unit	Minimum	Typical	Maximum	Comment
Range	Hz	0	—	10000	In steps of 1 Hz
Range (phase and quad)	Hz	0	—	5000	In steps of 1 Hz
Rising voltage threshold	V	—	—	4.25	Voltage required for frequency input
Falling voltage threshold	V	0.97	—	—	Voltage required for frequency input
Input impedance	k Ω	232	233	234	No pull up or pull down
Input impedance (5V/GND)	k Ω	13.9	14.1	14.3	Pull up or pull down
Input impedance (2.5V)	k Ω	7.1	7.3	7.4	Pull up and pull down

Resistance input

Description	Unit	Minimum	Typical	Maximum	Comment
Range	Ω	6	—	10000	In steps of 1 Ω
Measurement error	%	—	—	7.1	100 Ω
		—	—	2.1	1k Ω
		—	—	5.4	10k Ω
Input impedance	Ω	1320	1320	1330	No pull up or pull down

Input/output types and specifications

Current input (4-20 mA)

Description	Unit	Minimum	Typical	Maximum	Comment
Minimum discernible current	mA	—	—	0.12	—
Maximum discernible current	mA	28.2	28.9	29.7	—
Resolution	μA	—	7	—	—
Worst case offset and gain error	μA	—	—	±743	$I_{\text{Measure}} = 28.9 \text{ mA}$
Non-linearity	μA	—	—	±42	—
Input impedance	Ω	197	200	202	No pull up or pull down

CAN shield and analog input

CAN Shield

Description	Unit	Minimum	Typical	Maximum	Comment
Input impedance	—	—	$0.68\mu\text{F} + 1\Omega$	—	—

Analog input

Description	Unit	Minimum	Typical	Maximum	Comment
Minimum discernible voltage	V	—	—	0.03	—
Maximum discernible voltage	V	5.64	5.78	5.92	—
Resolution	mV	—	1.4	—	—
Worst case offset and gain error	V	—	—	±0.14	$V_{\text{Measure}} = 5.78 \text{ V}$
Non-linearity	mV	—	—	±8.5	—
Input impedance	kΩ	230	233	236	—

Digital output

Low side digital output

Description	Unit	Minimum	Typical	Maximum	Comment
Voltage	V	0	—	V_{in}	$I_{\text{out}} = 500\text{mA}$
Current	mA	0	—	500	—

Input/output types and specifications

CAN communication

Description	Unit	Minimum	Typical	Maximum	Comment
Available Baud rates	kbps		50		With 120 Ω termination. The default baud rate is 250 kbps.
			100		
			125		
			250		
			500		
			1000		
Maximum input voltage range	V	-27	—	40	CAN+ and CAN-

Software updates using CG150 are supported via CAN0 and CAN1 channels.

USB communication

Description	Unit	Minimum	Typical	Maximum	Comment
Available Baud rates	Mbps	12	—	480	—
Maximum input voltage	V	-0.3	—	7.3	D+, D-, and VBUS

RS232 communication

Description	Unit	Minimum	Typical	Maximum	Comment
Available Baud rates	bps	—	9600	—	
			11400		
			19200		
			28800		
			38400		
			57600		
			115200		
Maximum input voltage	V	-25	—	25	Rx
		-13.2	—	13.2	Tx

Sensor output

Description	Unit	Min.	Typ.	Max.	Comment
Sensor Output Voltage (5V)	V	4.85	5	5.15	
Sensor Output Voltage (8V)	V	7.75	8	8.25	
Sensor Output Current (5V)	mA			250	
Sensor Output Current (8V)	mA			150	

Video power

Description.	Unit.	Min.	Typ.	Max.	Comments
Output Voltage (12V)	V		12		
Output Voltage (24V)	V		24		

Input/output types and specifications

Description.	Unit.	Min.	Typ.	Max.	Comments
Output Current (12V)	mA			750	
Output Current (24V)	mA			375	

Ethernet

Description.	Unit.	Min.	Typ.	Max.	Comments
Available Baud Rates	bps		10M		10M is default
			100M		
Max Input Voltage Range	V	-25	-	25	Receiver Input

Product ratings

DM1x00 environmental testing criteria

Climate environment

Description	Applicable standard	Comment
Storage temperature	IEC 60068-2-1, test Ab, IEC 60068-2-2 test Bb	
Operating temperature	IEC 60068-2-1, test Ab, IEC 60068-2-2 test Bd	
Thermal and humidity cycle	IEC 60068-2-38 (partial)	
Degree of protection	IEC 60529	

Chemical environment

Description	Applicable standard	Comment
Chemical resistance	ISO 16750-5	

Mechanical environment

Description	Applicable standard	Comment
Vibration	IEC 60068-2-64 test Fh	3.17g
Bump	IEC 60068-2-27 test Eb	
Shock	IEC 60068-2-27 test Ea	50g
Free fall	IEC 60068-2-31 test Ed	

Electrical/electromagnetic

Description	Applicable standard	Comment
EMC emissions	ISO 13766	Electromagnetic compatibility for earth moving machinery.
EMC immunity	ISO 13766	Electromagnetic compatibility for earth moving machinery.
ESD	EN61000-4-2	
Auto electrical transients	ISO 7637-2, ISO 7637-3	
Short circuit protection	Danfoss test	Inputs and outputs survive continuous short circuit. Normal function resumes when short is removed.
Reversed polarity protection	Danfoss test	Survives reverse polarity at supply voltage for at least five minutes.

Supply voltage/maximum current ratings

DM1x00 displays are designed to operate with a nominal 9 to 36 Vdc power supply with reverse polarity protection.

Supply voltage/maximum current ratings

Description	Unit	Minimum	Typical	Maximum	Comment
Operating temperature	°C	-30	—	+70	
Storage temperature	°C	-40	—	+85	
DC supply voltage	V	8	—	36	Normal operation.
		8	—	36	Cranking; reduced functionality.
		-36	—	36	Short circuit and reversed polarity protection.

Product ratings

Supply voltage/maximum current ratings (continued)

Description	Unit	Minimum	Typical	Maximum	Comment
DM1000 variants	A	—	1.7	—	Vin = 8V
		—	1	—	Vin = 14V
		—	0.45	—	Vin = 27V
		—	0.3	—	Vin = 36V
DM1200 variants	A	—	2.8	—	Vin = 8V
		—	1.4	—	Vin = 14V
		—	0.75	—	Vin = 27V
		—	0.5	—	Vin = 36V
+5V output voltage	V	4.75	5	5.09	Normal operation over temperature.
		0	—	36	Short circuit protection.
+5V output current	mA	—	—	100	
Short circuit pin voltage	V	0	—	36	All DEUTSCH connector pins.

Ingress Protection (IP) rating

DM1x00 displays carry Ingress Protection rating of IP66 and IP67 in the front and back.

Mounting the displays with Danfoss Mounting Kit gasket ensures IP66 rating when panel mounted.

Installation

DM1x00 Series Displays dimensions

Dimensions in mm [in], RAM mount and connector call outs

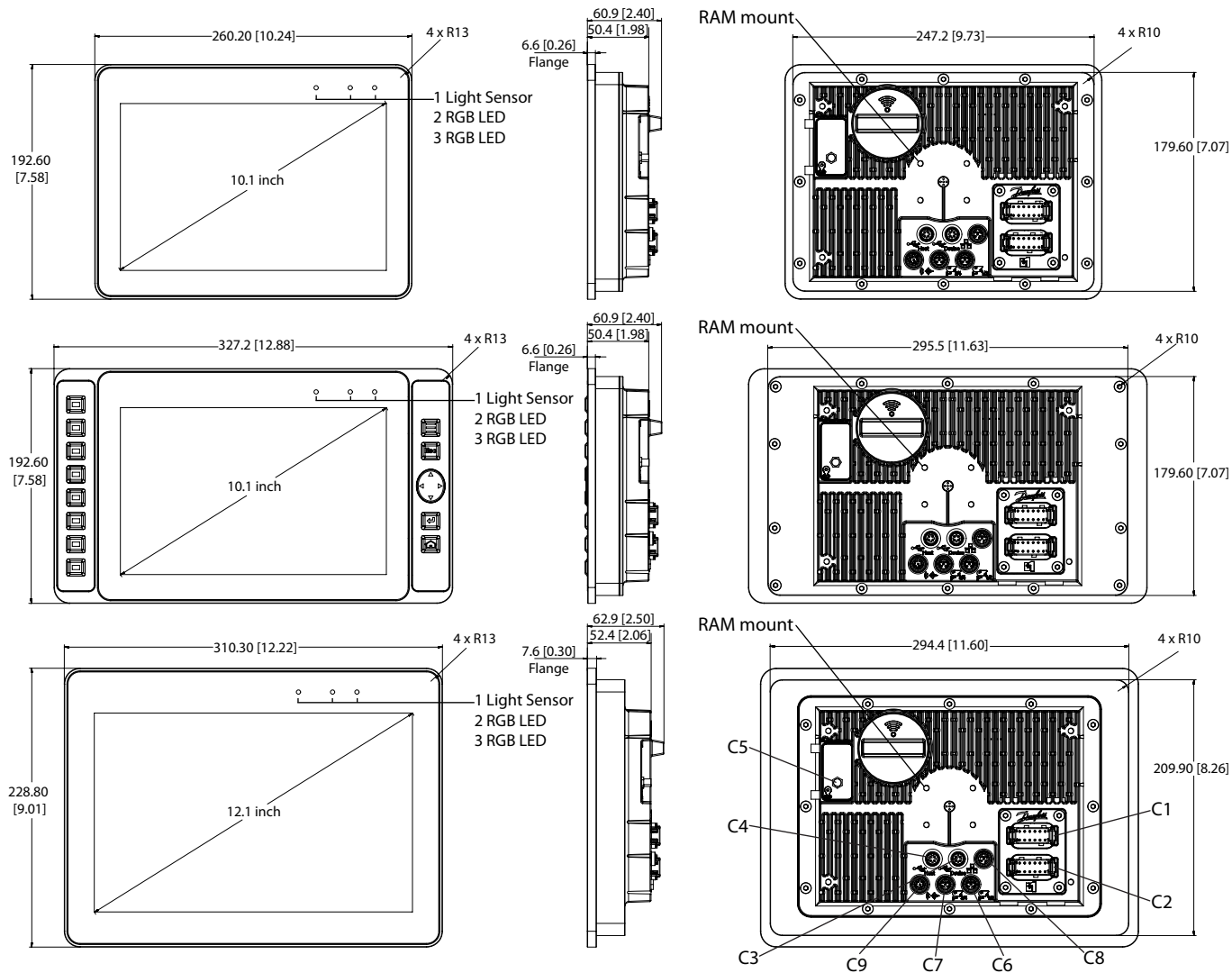

Button options

Standard (left) and Navigation (right) button options

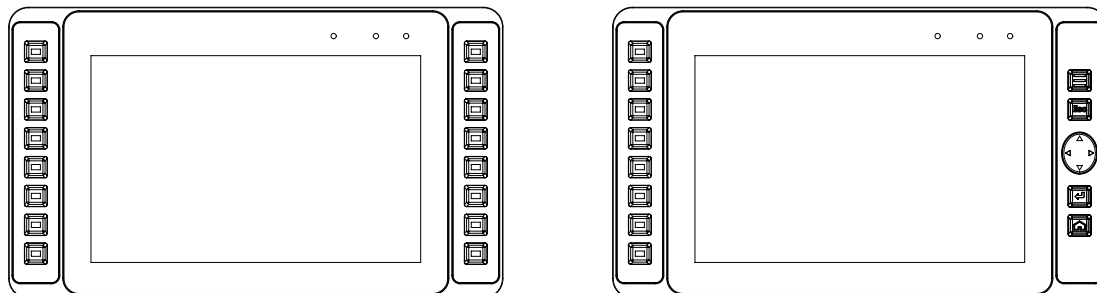

Installation

Pin assignments C1—C9

C1—DEUTSCH DTM06-12SA

Pin	Name
1	Battery Ground
2	Battery Power
3	CAN0+
4	CAN0-
5	DigIn/AnIn/CAN Shield
6	CAN1+
7	CAN1-
8	+5V SNSR
9	Ignition Input (K15)
10	Multifunction input (DigIn/AnIn/Freq/4-20 mA/Rheostat)
11	Multifunction input (DigIn/AnIn/Freq/4-20 mA/Rheostat)
12	DigiOut

C2—DEUTSCH DTM06-12SB

Pin	Name
1	Sensor Ground
2	DigiOut
3	CAN2+
4	CAN2-
5	DigIn/AnIn/CAN Shield
6	CAN3+
7	CAN3-
8	Multifunction input (DigIn/AnIn/Freq/4-20 mA/Rheostat)
9	Multifunction input (DigIn/AnIn/Freq/4-20 mA/Rheostat)
10	Walks Input (Digital Input)
11	DigiOut
12	DigiOut

C3—USB Device M12 4 Pin, Male, 'A' key

Pin	Name
1	USB D+
2	USB D-
3	USB VBUS
4	Ground

C4—USB Host M12 4 Pin, Male, 'B' key

Pin	Name
1	Host Data +
2	Host Data -
3	Host Vbus
4	Ground

Installation

C5—GNSS Antenna SMA Coaxial

Pin	Name
1	TxD+
2	RxD+
3	TxD-
4	RxD-

C6—Video M12 5 Pin, Female Primary

Pin	Name
1	RS232 TxD
2	RS232 RxD
3	RS232 Gnd
4	NC
5	Audio Left
6	Audio Right
7	Audio Gnd
8	NC

C7—Video M12 5 Pin, Female Secondary

Pin	Name
1	Pwr Ground
2	Pwr Supply
3	Signal In 1
4	Signal Ground
5	Signal In 2

C8—Ethernet M12 4 Pin, Female

Pin	Name
1	Pwr Ground
2	Pwr Supply
3	Signal In 3
4	Signal Ground
5	Signal In 4

C9—RS232/Stereo M12 8 Pin, Female

Pin	Name
1	TxD
2	RxD
3	Ground
4	Manufacturing Use Only (Leave Floating)
5	Left Channel
6	Right Channel
7	Ground
8	NC

Installation

Standard Mount

Standard mounting procedure

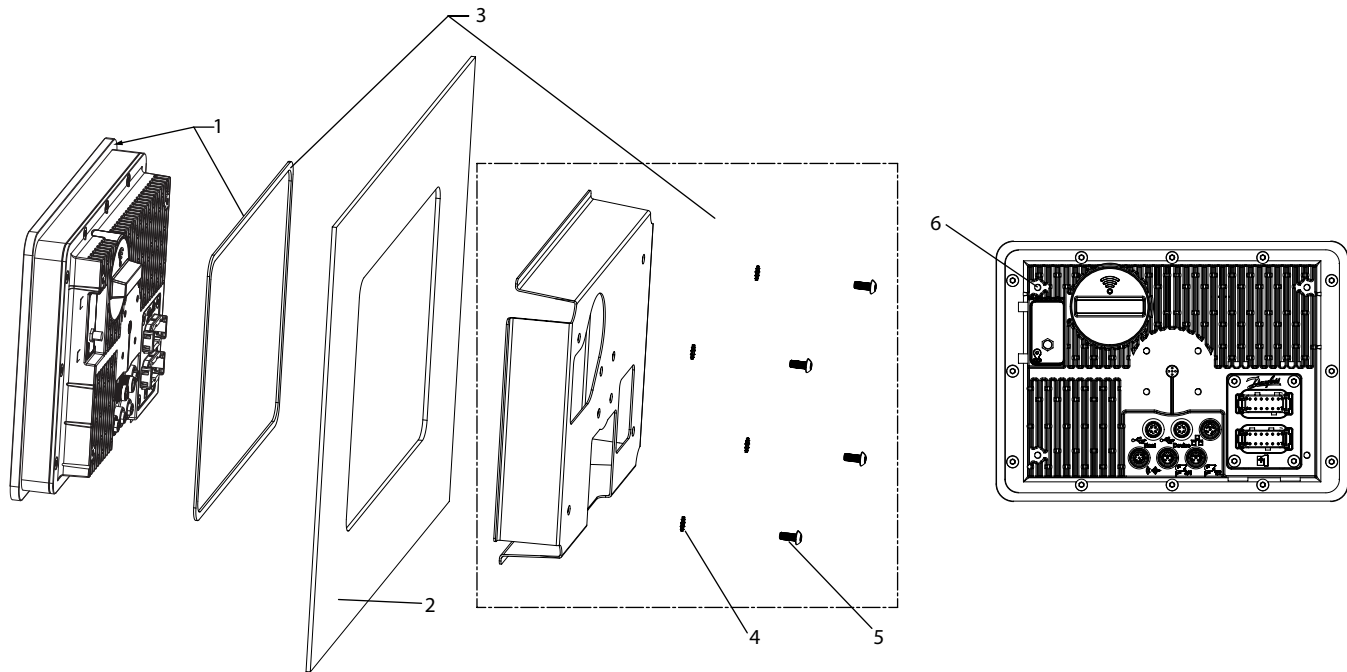

Call out	Description
1	Panel gasket (self sticks to housing, stays put during installation)
2	Mounting panel
3	Panel mounting kit
4	External tooth lock washers x 4
5	Fastening screws: 4xM5x0.8 thread type
6	Mounting hole depth: 12 mm [0.47 in] deep Torque: 4.5 N-m [39.8 in-lbs]

Panel mounting kit

Quantity	Description
4	Screws
4	Washers
1	Gasket
1	Bracket

Installation

Mounting panels cutouts

Panels cutouts with dimensions in mm [in]

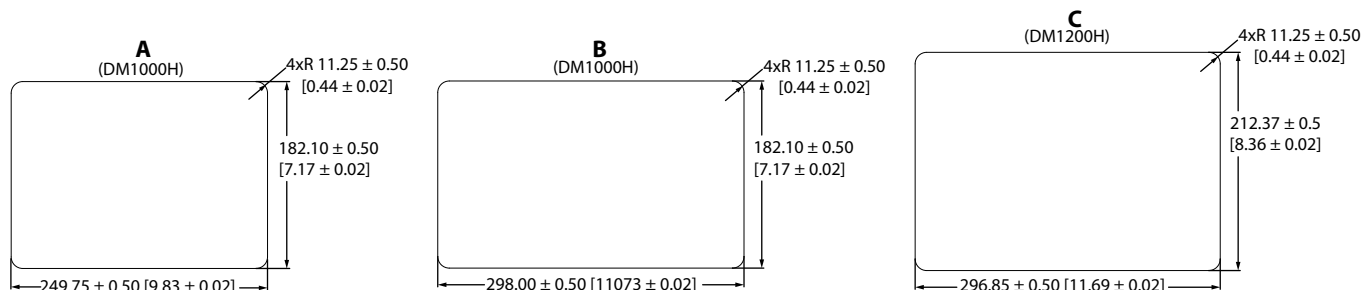

A	Panel cutout for DM1000H without buttons
B	Panel cutout for DM1000H with buttons
C	Panel cutout for DM1200H

RAM mount

Ram mounting procedure

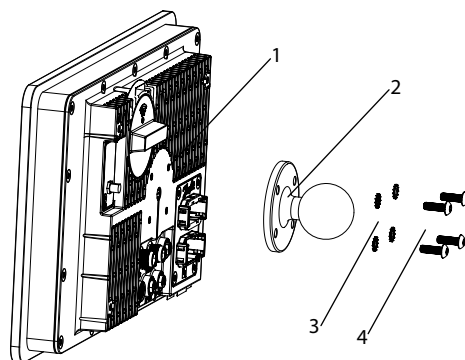

RAM mount parts

Call out	Description
1	RAM post mount hole pattern
2	Ball size: 38 mm [1.5 in] Size C
3	External tooth lock washers x 4
4	RAM fastening screws: 4xM5x0.8 thread type Mounting hole depth: 11 mm [0.43 in] deep Torque: 4.5 N-m [39.8 in-lbs].

Installation

Fastening

 **Caution**

- Use of non-recommended screws can cause damage to housing.
 - Reassembly with self-tapping screws can damage existing threads in housing.
 - Oversized panel cutouts can jeopardize product IP rating.
 - Ensure the vent is not covered. This excludes the RAM mount option.
 - Do not block the vent patch holes when fastening hole depth
-

Installation

Visibility and viewing radius

Due to the display nature of the TFT-LCD screen, the optimal viewing angle for the DM1x00 series displays are at a maximum radius of 85° from either side of the screen.

Optimal viewing angle

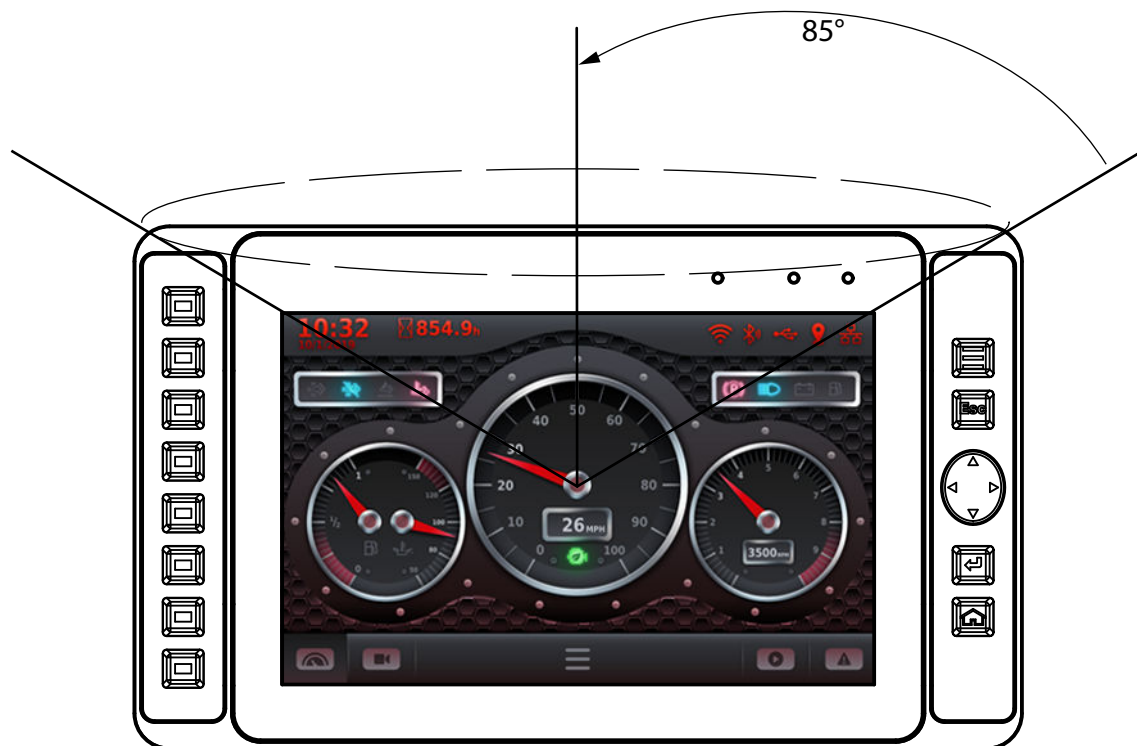

Display faulty application recovery

The boot loader is always executed when the unit is powered. The boot loader checks if the application has the completely downloaded flag set and in that case starts to execute it after a delay of 200 ms. The delay gives an opportunity for the PLUS+1® Service Tool to prevent the call to the application. This allows a non functional application to be replaced by the boot loader. This recovery function is activated by the **Communication > Recover ECU** menu in the PLUS+1® Service Tool.

Cleaning

Do not pressure wash. Clean using a dry, soft, lint-free cloth, such as a micro-fiber cloth.

Products we offer:

- DCV directional control valves
- Electric converters
- Electric machines
- Electric motors
- Hydrostatic motors
- Hydrostatic pumps
- Orbital motors
- PLUS+1® controllers
- PLUS+1® displays
- PLUS+1® joysticks and pedals
- PLUS+1® operator interfaces
- PLUS+1® sensors
- PLUS+1® software
- PLUS+1® software services, support and training
- Position controls and sensors
- PVG proportional valves
- Steering components and systems
- Telematics

Danfoss Power Solutions is a global manufacturer and supplier of high-quality hydraulic and electric components. We specialize in providing state-of-the-art technology and solutions that excel in the harsh operating conditions of the mobile off-highway market as well as the marine sector. Building on our extensive applications expertise, we work closely with you to ensure exceptional performance for a broad range of applications. We help you and other customers around the world speed up system development, reduce costs and bring vehicles and vessels to market faster.

Danfoss Power Solutions – your strongest partner in mobile hydraulics and mobile electrification.

Go to www.danfoss.com for further product information.

We offer you expert worldwide support for ensuring the best possible solutions for outstanding performance. And with an extensive network of Global Service Partners, we also provide you with comprehensive global service for all of our components.

Hydro-Gear

www.hydro-gear.com

Daikin-Sauer-Danfoss

www.daikin-sauer-danfoss.com

Local address:

**Danfoss
Power Solutions (US) Company**
2800 East 13th Street
Ames, IA 50010, USA
Phone: +1 515 239 6000

**Danfoss
Power Solutions GmbH & Co. OHG**
Krokamp 35
D-24539 Neumünster, Germany
Phone: +49 4321 871 0

**Danfoss
Power Solutions ApS**
Nordborgvej 81
DK-6430 Nordborg, Denmark
Phone: +45 7488 2222

**Danfoss
Power Solutions Trading
(Shanghai) Co., Ltd.**
Building #22, No. 1000 Jin Hai Rd
Jin Qiao, Pudong New District
Shanghai, China 201206
Phone: +86 21 3418 5200

Danfoss can accept no responsibility for possible errors in catalogues, brochures and other printed material. Danfoss reserves the right to alter its products without notice. This also applies to products already on order provided that such alterations can be made without subsequent changes being necessary in specifications already agreed. All trademarks in this material are property of the respective companies. Danfoss and the Danfoss logotype are trademarks of Danfoss A/S. All rights reserved.