

Overrunning clutches

An overrunning clutch transmits rotary motion only in one direction. It is used to eliminate torque peaks generated by the inertia of implements with heavy rotating masses, such as rotors or flywheels during deceleration or stopping.

Combination friction clutches with overrunning clutches are usually mounted on implements with high rotary inertia (square balers or mower conditioners) in order to guard the driveline from possible torque peaks generated during both starting and stopping.

A standard overrunning clutch is designed to operate with counter-clockwise rotation of the driveline on which it is installed. This is the typical rotation of an overrunning clutch installed on the implement side of a driveline connecting a tractor's rear-mounted PTO (clockwise rotation viewed into the shaft) to the implement PIC (counter-clockwise rotation viewed into the shaft), as shown below.

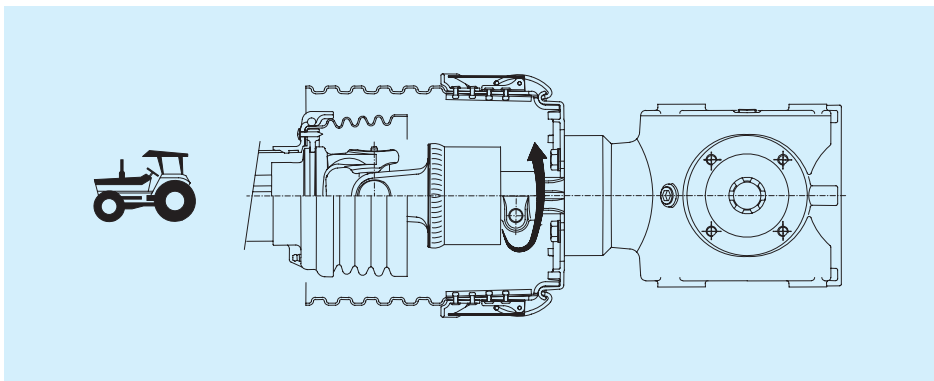
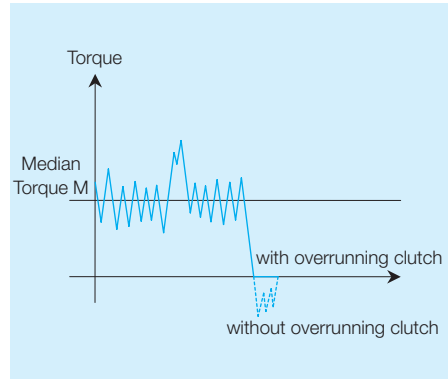

Overrunning clutches

Overrunning clutch RA

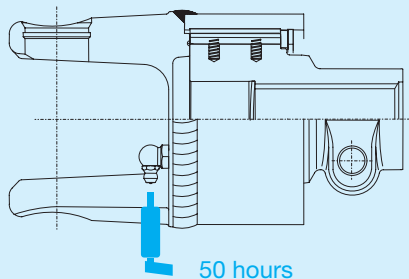

Overrunning clutch RL

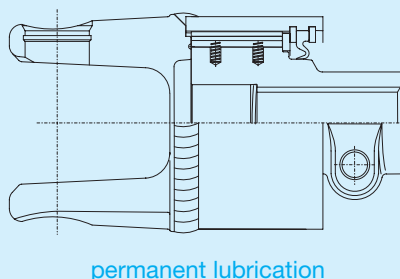

Two versions of overrunning clutches are available: RA and RL.

Version RA is equipped with a grease fitting and lubrication is recommended every 50 hours of use with NLGI grade 2 grease. Version RL has a special seal ring and locking plate located within the hub, to help prevent loss or contamination of the grease. RL overrunning clutches are lubricated with NLGI grade 2 molybdenum disulfide grease during assembly. No further lubrication is required for normal use, therefore no grease fitting is provided.

During normal operation (tractor driving implement), the pawls (either three or four pawls per clutch, depending on model) transmit motion from the housing to the hub.

During sudden deceleration or stopping, the driveline is driven by the inertia of the implement, which is connected to the hub of the overrunning clutch.

The pawls are depressed into grooves machined into the hub, and consequently motion is not transmitted to the housing or other driveline components.

The pawls, under pressure from the underlying springs, automatically reengage the grooves in the housing when transmission of motion is restored in the normal direction.

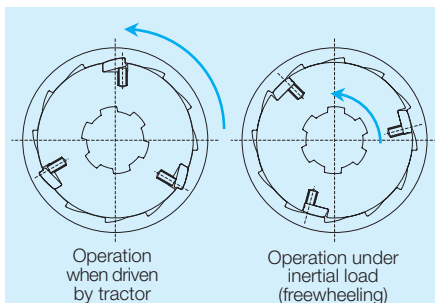
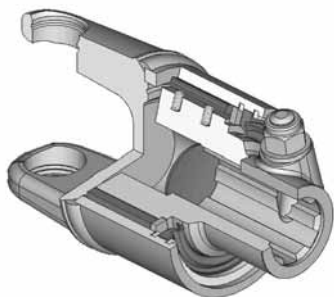

Overrunning clutches

The torque transmitted creates compressive stress in the pawls of the RA and RL overrunning clutches, for smoother and more reliable operation.

The pressure applied to the pawls is a function of the power transmitted. The length and number of pawls increase with larger driveline sizes. Three sizes of overrunning clutches are available, with different length of pawls and attachment to PTO.

RA1 and RL1

- Push-pin attachment for RA1
- Ball collar attachment for RL1

RA2 and RL2

- Taper pin attachment

RL3

- Taper pin attachment .

RL3 overrunning clutches are equipped with a ball bearing (shown below), in order to maintain stable alignment of the hub and housing during relative rotation (i.e. freewheeling).

For sizes SH and S0, the RL3 overrunning clutches are equipped with four pawls (instead of three as found in other models).

