

## Assembly Instructions for ES-4 Tube Couplings

### 1. Notes

These assembly instructions describe the two assembly options provided for in the German standard DIN 3859 Part 2:

- Direct assembly in the coupling connecting piece.
- Pre-assembly in hardened pre-assembly mandrel.

All the data below were determined under the following preconditions:

- Seamless steel tubes for precision applications to EN 10305-1.
- Tube material 1.0255+N to DIN 1630.
- Corrosion protection VOSS Zink-Nickel.

We recommend the use of VOSS pre-assembly devices for series-production assembly. The specifications in the respective operating instructions apply to the assembly procedures here.

Compliance with the assembly instructions is extremely important for fulfilling the functions of the ES-4 cutting ring couplings. Improper handling leads to risks with regard to safety and freedom from leaks, which can also result in the complete failure of the coupling under certain conditions.

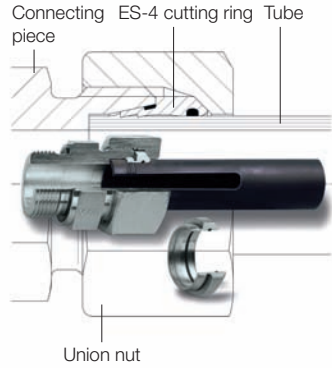

**Caution!**  
Please observe the safety instructions for installation and recommendation on the use of tube support (see VOSS Catalogue).

### 2. Tube preparation

2.1 Minimum dimensions of the straight tube ends must be taken into account for determining the tube lengths.

With machine pre-assembly, the minimum lengths are contained in the respective operating instructions of the pre-assembly devices.

Series	Tube-OD	H	L
L	6/ 8	31	39
L	10/12	33	42
L	15	36	45
L	18	38	48
L	22/28	42	53
L	35/42	48	60

Series	Tube-OD	H	L
S	6/ 8	35	44
S	10/12	37	47
S	14/16	43	54
S	20	50	63
S	25	54	68
S	30	58	72
S	38	65	82

2.2 Saw off tube at a right angle. An angular tolerance of  $\pm 1^\circ$  is permissible. Do not use tube cutters or abrasive cutting machines.

2.3 Slightly deburr tube ends inside and outside. Clean tube.

**Caution!**

- Burrs on the outside tube diameter can damage the inner O-ring.
- Tubes cut crooked or improperly deburred reduce the service life and freedom from leaks of the coupling.
- With thin-walled steel tubes or soft tubes of non-ferrous metals, reinforcing sleeves should be used (see VOSS Catalogue).

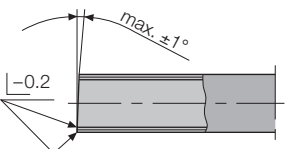
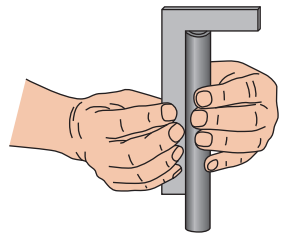
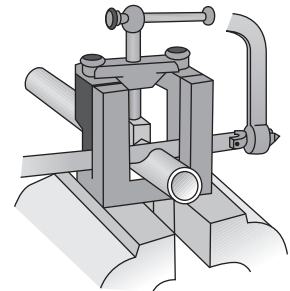
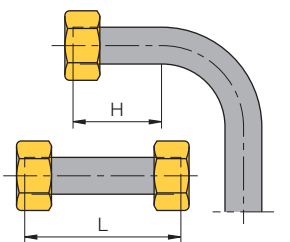

### 3. Assembly preparation

3.1 To simplify assembly, we recommend lubricating the thread and the taper of the coupling connecting piece or the manual pre-assembly mandrel.

3.2 Wetting of the tube end with lubricant makes it easier to push the ES-4 cutting ring onto the tube.

3.3 Push the union nut and the ES-4 cutting ring onto the tube end consecutively. The cutting edges of the ES-4 cutting ring face the tube end.

**Caution!**  
Ensure that the ES-4 cutting ring is positioned correctly, otherwise assembly will not be correct.

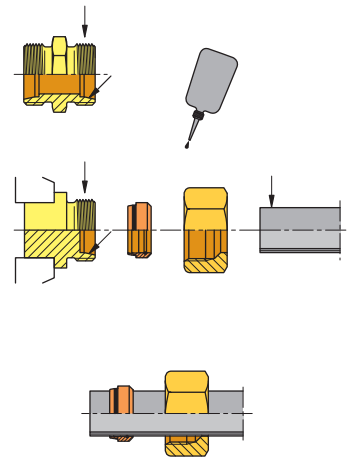

### 4. Direct assembly in coupling connecting piece

4.1 Insert the tube end into the coupling connecting piece as far as possible and press on. During the assembly process the tube must be held on the stop to prevent incorrect assembly.

4.2 Screw on the union nut by hand until the coupling connecting piece, the ES-4 cutting ring and the union nut are felt to make contact.

4.3 Tighten the union nut with approx. 1 1/4 turns (at least 1 to a maximum of 1 1/2 turns). When doing so, the ES-4 cutting ring contacts the connecting piece face.

**Notes:**

- For assembly within the tube, tighten the coupling connecting piece with a spanner.
- To comply with the specified number of turns, it is recommended that marking lines be applied to the union nut and the tube.

**Caution!**

- Each coupling connecting piece may only be used once for initial assembly. In the case of multiple use, malfunctions can occur.
- Following assembly a visual inspection including checking of the correct assembly results is absolutely necessary (see point 6. Checking).

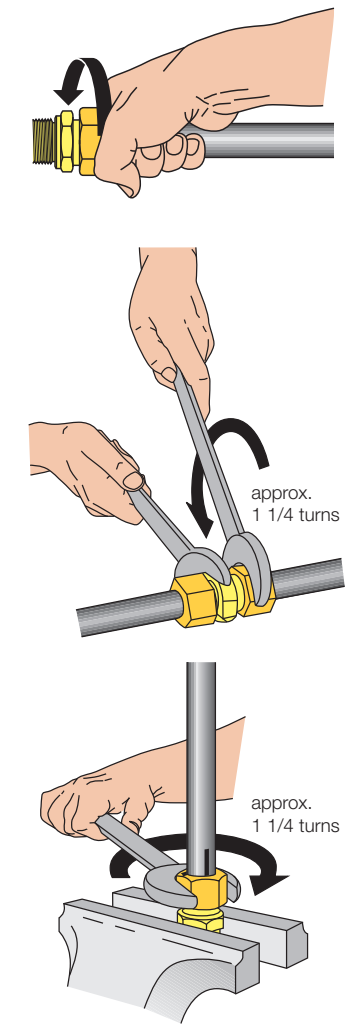

### 5. Pre-assembly in hardened pre-assembly mandrel

The hardened pre-assembly mandrels are wear-resistant and enable uniform assembly results, as they are more closely toleranced. They should be checked for trueness to gauge size after approx. every 50 pre-assemblies.

Replace pre-assembly mandrels which are not true to gauge size or are damaged in the cone area to prevent incorrect assembly.

5.1 Insert the tube end into the pre-assembly mandrel as far as possible and press on. During the assembly process the tube must be held on the stop to prevent incorrect assembly.

5.2 Screw on the union nut by hand until the pre-assembly mandrel, the ES-4 cutting ring and the union nut are felt to make contact.

5.3 Tighten the union nut with approx. 1 1/4 turns (at least 1 to a maximum of 1 1/2 turns). When doing so, the ES-4 cutting ring contacts the pre-assembly mandrel face.

**Caution!**  
Following each pre-assembly a visual inspection including checking of the correct assembly results is absolutely necessary (see point 6. Checking).

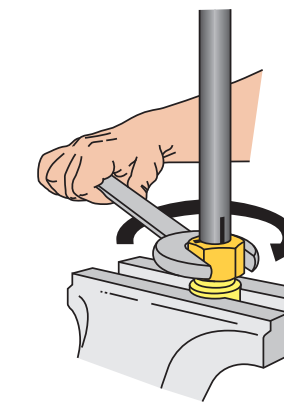
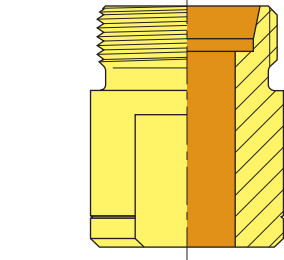

### 6. Checking

6.1 Unscrew the union nut and check the shoulder throw-up, gap width and the moulded seal. The shoulder throw-up must cover at least 80 % of the cutting-edge face surface. The moulded seal must not be damaged. Remove possible soiling and replace the moulded seal if necessary.

6.2 Due to slight springing back during disassembly of the tube coupling, a gap of approx. 0.5 mm results between the ES-4 cutting ring and the coupling face (or pre-assembly coupling piece face). This gap is closed again during finish assembly.

**Caution!**

- With a different gap width or an insufficient shoulder throw-up, repeat assembly with increased force and check again.
- It may still be possible to turn the ES-4 cutting ring on the tube.

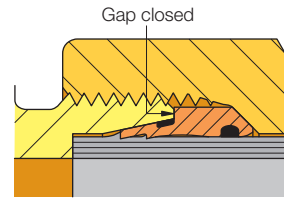
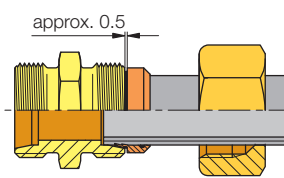
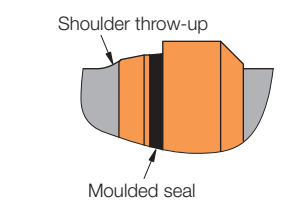

### 7. Finish assembly

7.1 Carefully reinsert the tube end mounted in the coupling connecting piece in which it was assembled. When inserting, make sure that the moulded seal is not damaged and lies properly in the seal groove. Then tighten the union nut hand-tight and stress-free.

7.1.1 Tighten the union nut with the spanner with the same amount of force as during initial assembly. When doing so, the ES-4 cutting ring firmly contacts the connecting piece face.

7.2 Carefully insert the tube end pre-assembled in a (new) coupling connecting piece not yet used for assembly and tighten the union nut hand-tight and stress-free. When inserting, make sure that the moulded seal is not damaged and lies properly in the seal groove.

7.2.1 Tighten union nut with spanner (without extension) up to noticeable increase in force.

7.2.2 Then tighten another 1/4 turn. When doing so, the ES-4 cutting ring contacts the connecting piece face gap-free again.

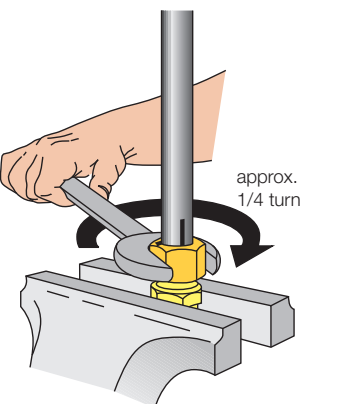
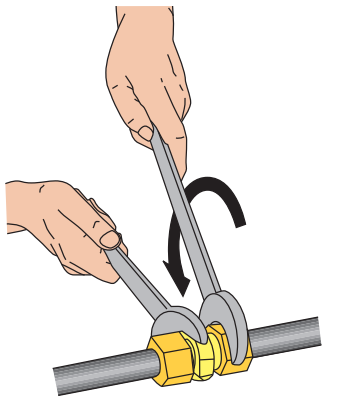

### 8. Repeat assembly

8.1 Each time the tube coupling is unscrewed, the moulded seal must be checked for damage and replaced if necessary.

8.2 In case of repeat finish mounting, the union nut must be tightened again with the same amount of force as during initial assembly.

**Caution!**  
The assembly result, such as the shoulder throw-up, moulded seal and gap, must be checked (see 6. Checking).

