

INSTALLATION MANUAL

REMOTUS T-Rx Std. T-Rx Std. 500, T-Rx Std. Era 8B, T-Rx Std. 12B/12BD

(RXO, AQ80, TX52/55)



Revision history

Version	Date	Reason
A0	2014-12-16	1 st released version
A1	2015-03-30	Chapters have been moved for better flow and clarifying in the program selection
A2	2015-08-28	Program Option 4 added
A3	2015-11-30	Program Option 5 added

Reference

RXO manager, manual 949689-000.

Display control mapping RXO Std. manual 951571-000.

Table of Contents

1	Introduction	5
2	Scope	5
3	Use of warnings and notes in this manual	6
4	Warnings regarding installation and maintenance work	6
5	Specifications	7
5.1	Design	7
5.2	Functional description	8
6	Installation	9
6.1	Installation preparation	9
6.2	Mechanical installation	10
6.2.1	Connecting earth to receiver housing	10
6.3	Connections and switches on the MAIN board	11
6.4	Cable installation	11
6.4.1	Connecting power supply	12
6.4.2	Serial interface cabling	12
6.4.3	Connecting output interface to control equipment	13
6.4.4	Functional diagram	13
6.4.5	Principle connection of the Main contactors	14
6.5	Antenna installation	14
7	Program Selection	15
7.1	Program Selection list	15
7.1.1	Program Option 0	15
7.1.2	Program Option 1 - Shift function	16
7.1.3	Program Option 2 - Interlocking between the button pair	17
7.1.4	Program Option 3 - Interlocking between the button pair, Shift function	18
7.1.5	Program Option 4 - Interlocking between the button pair, High speed	19
7.1.6	Program Option 5 - Interlocking between the button pair, separate high speed	20
8	Derating	21
8.1	Convection cooling	21
9	Commissioning	22
9.1	Frequency setting	22
9.1.1	Radio frequency setting in Receiver RXO	22
9.2	Overview transmitters	23
9.2.1	Place symbol label	23
9.3	AQ80 Transmitter configuration mode	24
9.3.1	Shutdown Time of the Transmitter	24
9.3.2	PIN-code Configuration of the Transmitter	25
9.3.3	Radio Frequency Setting in the AQ80 Transmitter	25
9.3.4	Adjustment of the Push Buttons Remaining and Momentary Functions	28
9.3.5	Radio communication power	28
9.3.6	FX sequence	28
9.3.7	System info	28
9.4	TX52/55 Transmitter configuration	29
9.4.1	Shutdown time	29
9.4.2	PIN Configuration	29
9.4.3	Radio Frequency Setting in the TX52/55 Transmitter	30
9.4.4	Adjustment of the push button functions	31

9.5	Pairing of transmitter and receiver	32
9.5.1	Pairing indications	32
9.6	CIM Card	33
9.6.1	Removing/Mounting CIM Card AQ80	33
9.6.2	Removing/Mounting CIM Card TX52/55	33
10	Function tests	34
11	Indications	34
11.1	Receiver indications	34
11.2	Transmitter indications	35
11.2.1	Status indicator	35
11.2.2	Display indications	35
12	Trouble shooting	36

List of figures

Figure 1.	Receiver functional safety description	8
Figure 2.	Receiver mounting dimension	10
Figure 3.	Receiver front side	10
Figure 4.	Receiver back side	10
Figure 5.	Connections, switches, interface terminals and LED on the MAIN board	11
Figure 6.	Installation of cables	11
Figure 8.	Connection with the two main contactors in parallel, category 3	14
Figure 9.	Connection with the two main contactors in series, category 1	14
Figure 10.	Convection cooling. Maximum allowed output current versus ambient temperature	21

List of tables

Table 1.	Technical specifications	7
Table 2.	Fixed frequency list	27
Table 3.	Frequency setting list for TX52/55	30
Table 4.	Receiver pairing indication	32
Table 5.	Transmitter pairing indication	32
Table 6.	Transmitter display pairing indication	32
Table 7.	Indications on the Receiver back side	34
Table 8.	Indications of the transmitter's status indicator	35

1 Introduction

Remotus is Åkerströms product family for radio remote control of safety critical industrial and mobile applications. Remotus T-Rx Std. is Åkerströms' standardized mobile remote control product line.

The manual must be used when installing Åkerströms Remotus system to ensure a secure and safe operation. This manual only covers the installation of the Remotus radio remote control system. Remotus does not include a complete system for remote control: it has only a set of outputs that is controlled by the operator with the transmitter switches and joysticks. How the outputs are used to control the object (for example, a machine's movements and brakes) depend on the specific installation and is outside the scope of the Remotus system.

It is the responsibility of the Systems Integrator or Machine builder to safely incorporate the Remotus radio remote control into the complete system or machine. The System Integration has to be made by qualified personnel applying the appropriate standards for the system or machine including making the necessary safety investigations and risk analysis.

It should be noted that the information obtained from the controlled object is not processed by the Remotus receiver, but is used for informational purposes.

For the reasons stated above, the safety of Remotus covers mainly the status of the relay outputs, regardless of the object that is controlled by the relays.

The interface between Remotus and the controlled object should be a special interface that is not included in Remotus system and therefore is not included in this installation manual.

The approvals for Remotus refer only to the Remotus system not the complete system.

The complete radio control system must be tested and approved in accordance with applicable standards. It is not part of Åkerströms Björbos responsibility.

2 Scope

The Remotus T-Rx Std. system described in this manual consists of one receiver and one transmitter.

	Type	Model
Receiver	RXO	T-Rx Std. 500
Button transmitter	AQ80	T-Rx Std. Era 8B
	TX52	T-Rx Std. 12B
	TX55	T-Rx Std. 12BD

3 Use of warnings and notes in this manual

Read all safety instructions throughout this manual and on safety signs attached to this equipment.

Failure to follow all safety instructions could result in death or serious injury.

The safety alert symbol is used to alert about potential personal injury hazards. To avoid hazards, obey all safety messages that follow this symbol. Inform all personnel that are working with the product.

The following safety alert symbols and signal words are used in this manual to inform the user of hazards.



Indicates a potentially risk of high voltage which, if not avoided, could result in death or serious injury or property damage.



Indicates a potentially hazardous situation which, if not avoided, could result in death or serious injury or property damage.



Indicates a condition which, if not avoided, could result in damage to or poor functionality of the product.

4 Warnings regarding installation and maintenance work

This manual must be read and understood before installing and starting the radio remote control system to ensure safe and secure operation.

The installation and/or maintenance work must be carried out by a qualified and educated person in accordance with country installation rules and regulations. Only a correct installation can ensure the necessary level of safety during use.



Before any work on the receiver disconnect the power supply.



Disconnect voltage when working with installation wiring.
Voltage may be supplied from different power sources.



As the antenna installation may require work to be carried out on the vehicle/machine roof care should be taken to protect personnel from falling.



Read the User Manual before attempting to use the transmitter.

If testing of the installation also includes moving, make sure no personnel or equipment is in the area of moving objects.



Disconnect voltage when connecting/disconnecting connectors.
Voltage may be supplied from different power sources.



At high ambient temperatures, the receiver units' surface gets hot. Do not touch the surface.
In these situations the receiver shall be installed out of reach.

5 Specifications

General:	
Operating frequency:	433-434 MHz
Power output:	< 10 mW
Baud rate:	9600 b/s
Transmission principle:	GFSK, TDMA
Channel Separation:	25 kHz
Functional sensitivity:	≤-107 dBm BER 10 ⁻³
The radio full-fills:	R&TTE Directive 99/5EC
Reaction time on STOP function:	Maximum 550 ms
Safety category for the Stop function	ISO 13849-1 Category 3 PL d
Receiver T-Rx Std. 500:	
Type:	RXO
Dimensions:	240x177x67.5 mm, connectors excluded
Weight:	1.6 kg
Power supply:	12 V DC nominal (6-16 V DC) max 0,35 A @12 V DC, outputs excluded 24 V DC nominal (10-21 V DC) max 0,175 A @12 V DC, outputs excluded
Operating temperature:	-25 °C - +70 °C
Storage temperature:	-40 °C - +85 °C
Degree of protection;	IP67
Transmitter T-Rx Std. Era 8B:	
Type:	AQ80
Dimensions:	181 x 65 x 43 mm
Weight:	265 g
Operating Temperature for battery:	-20 °C – +55 °C
Storage Temperature for battery:	-20 °C – +35 °C
Charging Temperature for battery:	+10 °C – +45 °C
	NOTE! For charging see charger documentation
External power supply voltage:	5 ± 0.25V 100mA max. Must be supplied with Limited Power Source (LPS)
Display:	Graphic LCD, 128x64 pixels
Transmitter T-Rx Std. 12B/BD:	
Type:	TX52/55
Dimensions TX52/55:	243 x 77 x 41 (49 mm incl. safety stop)
Weight:	450 g
Operating temperature:	-25 °C – +55 °C
Storage temperature:	-40 °C – +85 °C
Battery type:	Li-Ion 3.7V
Operating Temperature for battery:	-20 °C – +55 °C
Storage temperature for battery:	-20 °C – +35 °C
Charging temperature for battery:	+10 °C – +45 °C (NOTE! For charging see charger documentation)

Table 1. Technical specifications

5.1 Design

The RXO receiver consists of a MAIN board and a radio module. The radio module is located on top of the MAIN board.

The MAIN board holds all logic components, power supply and the connectors.

The enclosure is made of metal.

5.2 Functional description

The Remotus T-Rx Std. Era system uses a dual channel architecture in both the receiver and the transmitter to achieve high degree of safety. For additional safety the receiver RXO is equipped with two safety outputs intended for safety stop.

The dual channel architecture and extensive use of safety outputs in the receiver will significantly increase the safety of the crane system providing that the installation is carried out correctly. To achieve category 3 Pl d for the STOP function according to ISO 13849-1:2006 both safety stop outputs from the receiver shall be connected to two independent stop inputs on the machine (two safety stop channels).

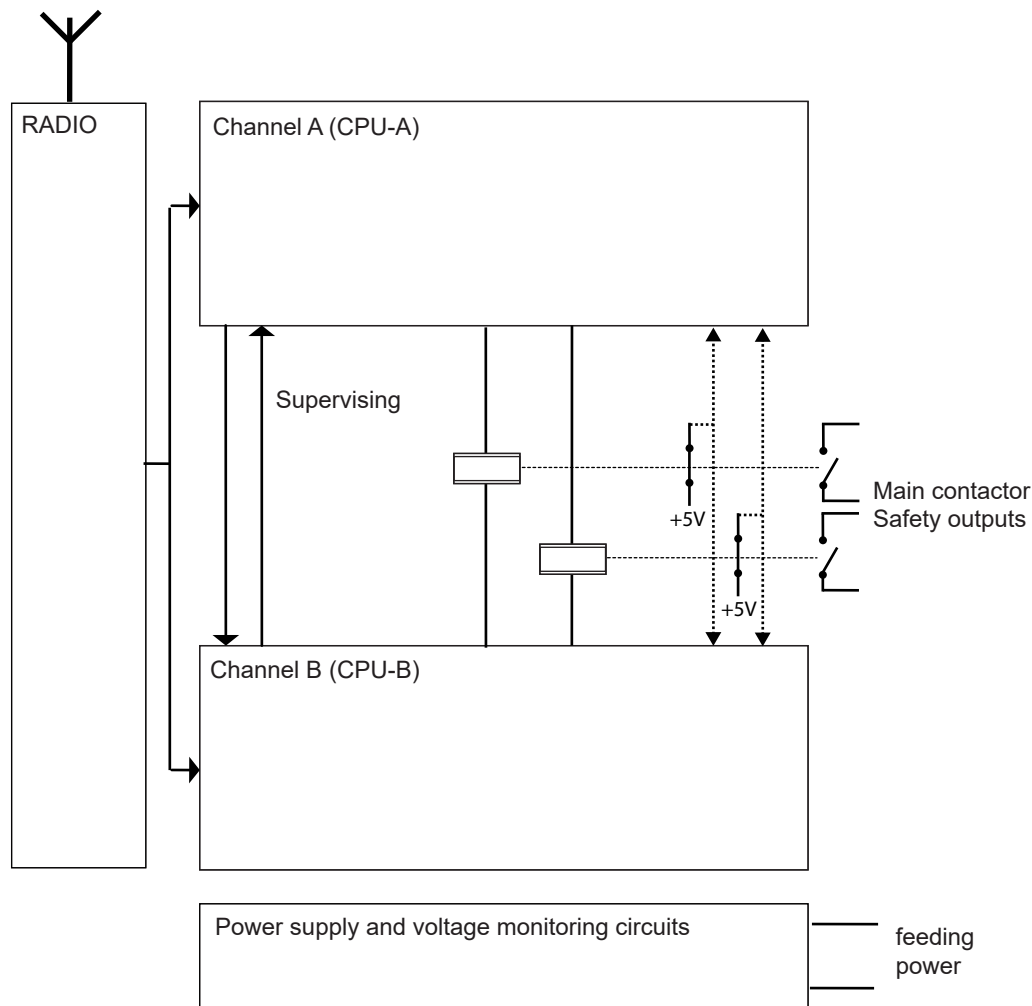

Figure 1. Receiver functional safety description

6 Installation

The installation shall be carried out by qualified personal. Ensure compliance to national and vehicle/machine depending installation regulations.

The permanent installation of the receiver must include fuses to protect the equipment and wiring from over current and short circuit. In detail the power supply of the receiver and all relay contacts must be fused. Over current protection for the receiver power supply and interface circuit is not provided with this enclosure. Over current protection must be provided as part of the installation.

6.1 Installation preparation

The T-Rx 500 receiver can be operated within a wide ambient temperature range according to the technical specifications below. Due to the additional self-heating, proper derating or cooling is needed.

See chapter “8 Derating”.

Select a proper space on the vehicle/machine for the receiver.

- The receiver shall be installed on a flat surface
- The receiver shall be protected against weather conditions and excessive mechanical damage
- The receiver must be fixed with four screws M5 x L
- ! Do not install the receiver close to heat generating equipment. As the internal heating of the device electronics is dissipated via the housing, sufficient cooling must be ensured in case of “sandwich mounting”
- ! Be sure to connect the earth from loads close to the RXO receiver earth to avoid risk of EMC interference
- ! Do not install the receiver close to equipment likely to produce radio interference disturbance
- ! Do not install on a structure that is prone to vibration

Make sure that it is possible to install the necessary cabling between the receiver and

- the antenna. Maximum cable length 10 m
- the vehicle/machine control system

The antennas shall be installed on the vehicle/machine on a conductive surface. See chapter “6.5 Antenna installation”.

- ! Do not install the antennas close to equipment likely to produce radio interference disturbance

6.2 Mechanical installation

Note! Make sure to install any optional accessories inside and/or on the receiver enclosure before mounting the receiver on the machine. Refer to each accessory kit for assembly instructions.

The receiver shall be installed on a flat surface or similar construction. Make sure that the structure may support the load of the receiver.

If possible the cable entry of the interface connector should be mounted pointing downwards. Mount the receiver using the mounting slots on each receiver end block as shown in Figure 2 below.

Fasten the receiver with four M5 screws. Fasten the screws with a torque of 2 Nm.

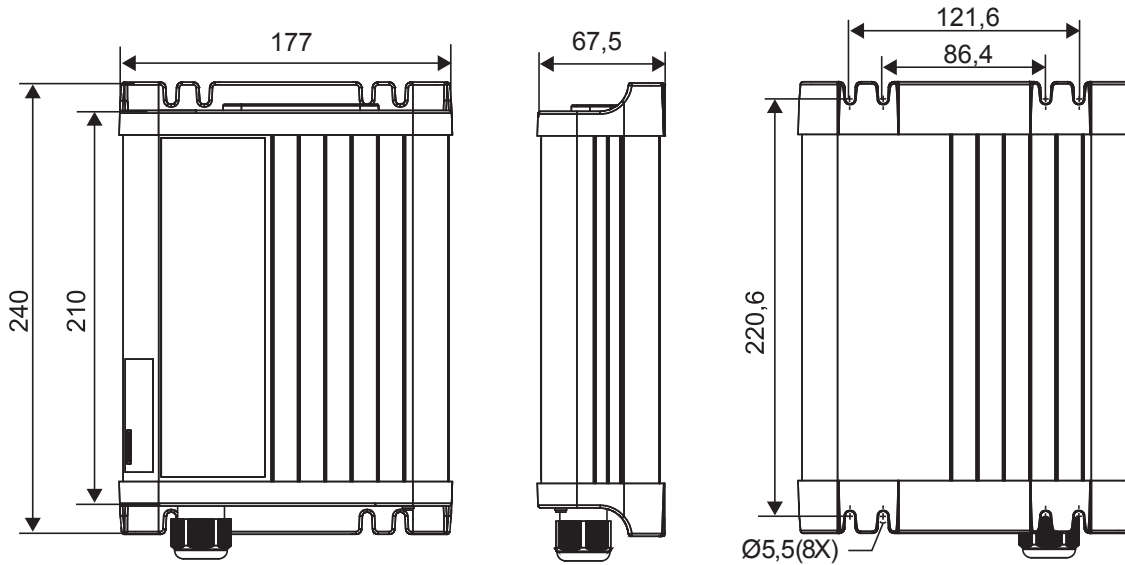

Figure 2. Receiver mounting dimension

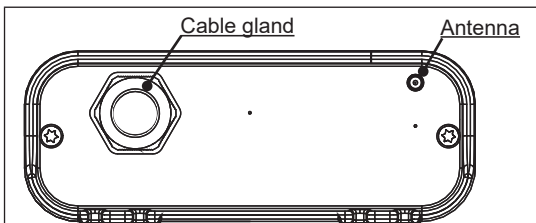

Figure 3. Receiver front side

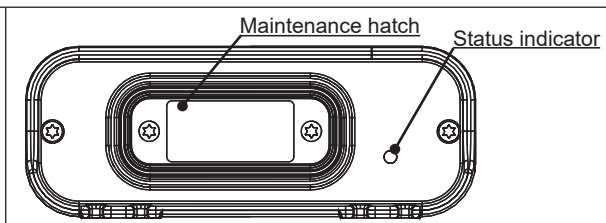

Figure 4. Receiver back side

6.2.1 Connecting earth to receiver housing

To ensure the receiver against electrical interference the housing shall be connected to ground. If a proper connection is not achieved by the fastening screws an additional earth cable shall be connected to one of the fastening screws of the receiver. Recommended wire size 2.5 mm².

For vehicles, ground refers to vehicle body.



Do not install the receiver on a vehicle/machine with positive grounding.

If the receiver is installed on an industrial truck the receiver must be mounted isolated from the frame. In the antenna cabling a DC block must be used.

Åkerströms can provide one suitable DC block 944498-000.

The insulation resistance between the receiver and the frame shall be at least 1000 Ω multiplied by the nominal voltage of the truck system according to EN 1175-1 + A1, Safety of industrial trucks - Electrical requirements - Part 1: General requirements for battery powered trucks.

6.3 Connections and switches on the MAIN board

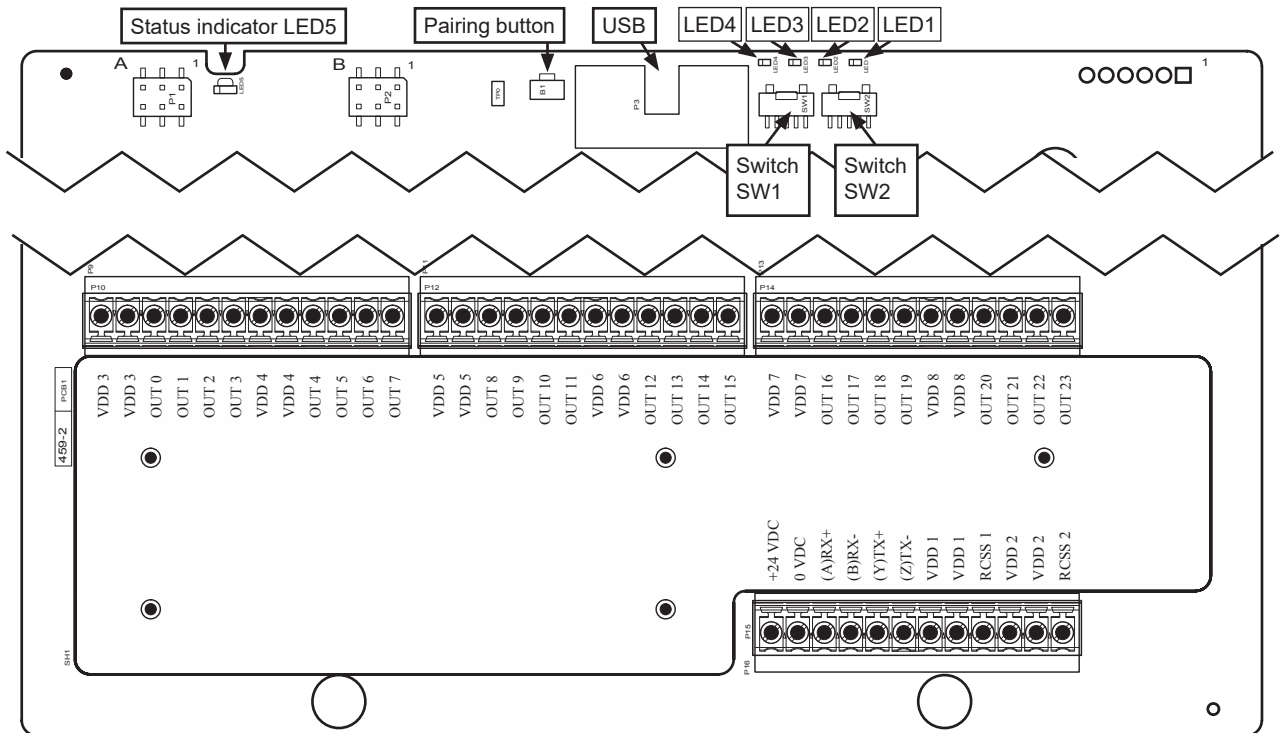

Figure 5. Connections, switches, interface terminals and LED on the MAIN board

6.4 Cable installation



Do not mix SELV and NON SELV signals in the same cable.



After the installation of the equipment, the installed cables must be bound together in pairs (e.g. by using a cable tie) very close to the terminal blocks (see Figure 6). This is important if a cable become loose. The cable should not be able to end up in an unsuitable location of the receiver. Fasten with a torque of 0.4-0.5 Nm.

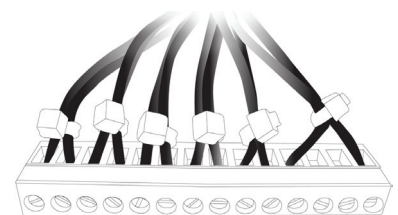

Figure 6. Installation of cables

6.4.1 Connecting power supply

The power supply is nominal 12/24 V DC, range 6-32 V DC. The input power supply wiring must be sufficiently fused, and if necessary it must be possible to disconnect manually from the DC mains supply.

Description	Terminal name	Fuse
Supply voltage receiver/analogue interface	VDD	max. 10 AT
Supply voltage output RCSS1	VDD 1	max. 10 AT
Supply voltage output RCSS2	VDD 2	max. 10 AT
Supply voltage output Digital 0-3	VDD 3	max. 10 AT
Supply voltage output Digital 4-7	VDD 4	max. 10 AT
Supply voltage output Digital 8-11	VDD 5	max. 10 AT
Supply voltage output Digital 12-15	VDD 6	max. 10 AT
Supply voltage output Digital 16-19	VDD 7	max. 10 AT
Supply voltage output Digital 20-23	VDD 8	max. 10 AT
Ground	GND	

! Both RCSS supply lines must be connected for correct functionality of the receiver.

6.4.1.1 Receiver supply

The maximum current consumption is 0.35 A at 12 V DC and 0.175 A at 24 V DC.

The fuse for the input power supply shall be max 10AT, and of slow blow characteristic and high breaking capacity.



If a switch is used for selecting Remote/Manual control the receiver and analogue interface supply (VDD) shall not be connected to the switch together with the supply for other outputs (VDD 1 - VDD 8).

6.4.1.2 RCSS Interface supply



The receiver has two safety outputs, RCSS1 and RCSS2. They shall be connected to the machine safety circuit in such a way that either one of them can stop the machine independently.

The current consumption on each RCSS feeding point is depending on the controlled devices connected to the output, but shall not exceed 3 A. The fuse for each RCSS feeding point shall be max10 AT, and of slow blow characteristic and high breaking capacity.

6.4.1.3 Digital Interface supply

Each feeding point supports four outputs. The current consumption on each feeding point is depending on the controlled devices connected to the outputs, but shall not exceed 3A/output or in all 4 A within the group. The fuse for each feeding point shall be max 10AT, and of slow blow characteristic and high breaking capacity.

6.4.2 Serial interface cabling

For the RS422/485 interface screened cables shall be used. The screen shall be connected to ground.

6.4.2.1 Serial port setup

To configure the serial port on RXO Std. use the RXO manager and please read section 6.4.3.1.3 to see the difference between connections of RS422 and RS485.

In RXO manager there are settings for baudrate, format and a choice between RS422 and RS485 interface. For information about how to control the display please read Display control mapping RXO Std. manual.

6.4.3 Connecting output interface to control equipment

The interface of the receiver consists of:

- 2 RCSS (Remote Control Safety Stop) outputs
- 24 Digital outputs
- 1 RS422 or RS485 interface

6.4.3.1 Connector pin assignment

6.4.3.1.1 RCSS outputs

Supply line terminal	Function output terminal
VDD 1	RCSS 1
VDD 2	RCSS 2

6.4.3.1.2 Digital outputs

Supply line terminal	Function output terminal
VDD 3	OUT 0-3
VDD 4	OUT 4-7
VDD 5	OUT 8-11
VDD 6	OUT 12-15
VDD 7	OUT 16-19
VDD 8	OUT 20-23

6.4.3.1.3 RS422/485 interface

RS422	RS485
Function output terminal	Function output terminal
Rx+	A
Rx-	B
Tx+	Y
Tx-	Z
GND	GND

6.4.4 Functional diagram

The receiver functional diagram shows how to connect the equipment, in this manual the functional diagram is written as different program options, see chapter 7.

6.4.5 Principle connection of the Main contactors

The radio remote control system is, for the safety stop function, designed for category 3 P1 d according to ISO 13849-1:2006. To achieve this safety level for the object (crane) both safety stop outputs MC1 and MC2 shall be used as two separate independent outputs (two safety channels). This means that there must be two main contactors on the machine. See the connection example below.

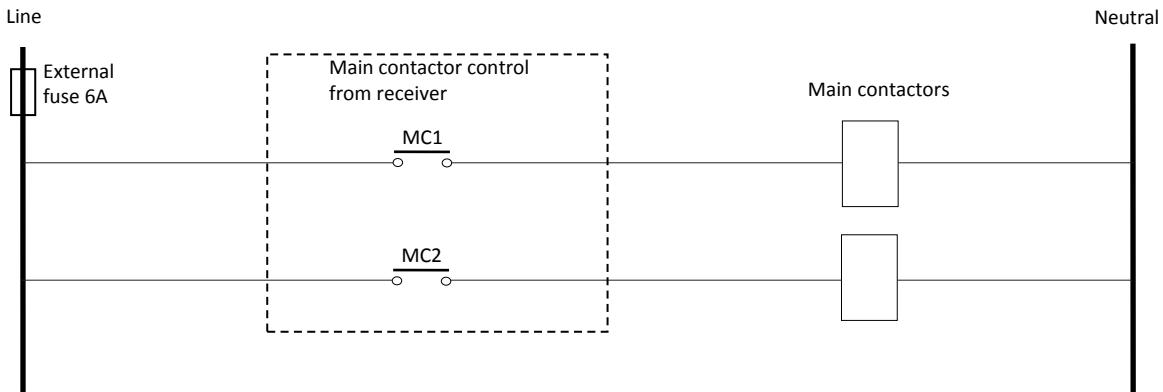

Figure 8. Connection with the two main contactors in parallel, category 3

If category 3 is not desired, the two safety stop outputs MC1 and MC2 shall be used connected in series. See the connection example below. The maximum level of safety for the safety stop function in this case will be category 1.

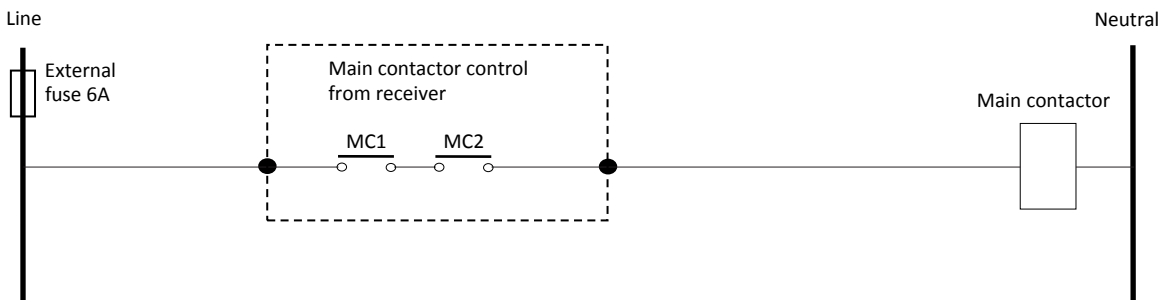

Figure 9. Connection with the two main contactors in series, category 1

6.5 Antenna installation

The antenna should be installed on a conductive surface with a minimum size of 50 x 50 cm. The surface shall be electrically connected to vehicle/machine chassis. The maximum allowed cable length between receiver and the antenna is 10 meters.

! Do not paint the antennas. Paint might considerable reduce the radio coverage area.

The maximum allowed length of the antenna cables is 10 meters.
 The connectors on the receiver are of type SMA for radio band 400MHz and 800MHz.
 Install the antenna cables separated from high voltage or high current cables/devices.



If the antenna is installed outdoors, there is a risk that dangerous voltages may enter the antenna cable. To minimize this risk a DC block shall be used. DC blocks are coaxial components that prevent the flow of low and direct current (DC) frequencies while offering minimum interference to RF signals. Suitable models have capacitors in series with both the inner and outer conductors.

Åkerströms can provide one suitable DC block 944498-000.

7 Program Selection

There are two rotary switches for program selection in the receiver, located behind the service hatch, see “Figure 4. Receiver back side” on page 10.

! Note! The switches must be set to the same position
 Example: Program option 0, set both switches to 0 (0,0)

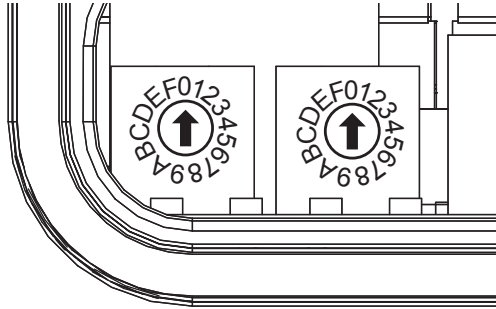

7.1 Program Selection list

7.1.1 Program Option 0

Program Option 0				
Supply line terminal	Connector	Function		Cable part
		8B	12B/12BD	
VDD3 Cable part:	OUT0	-	Button 1	
	OUT1	-	Button 2	
	OUT2	-	Button 3	
	OUT3	-	Button 4	
VDD4 Cable part:	OUT4	Button 1	Button 5	
	OUT5	Button 2	Button 6	
	OUT6	Button 3	Button 7	
	OUT7	Button 4	Button 8	
VDD5 Cable part:	OUT8	Button 5	Button 9	
	OUT9	Button 6	Button 10	
	OUT10	Button 7	Button 11	
	OUT11	Button 8	Button 12	
VDD8 Cable part:	OUT23	Activation output	Activation output	
VDD1 Cable part:	RCSS 1	RCSS 1		
VDD2 Cable part:	RCSS 2	RCSS 2		
Cable part:	+ 24VDC	+ 24VDC		
Cable part:	0VDC	0VDC		

7.1.2 Program Option 1 - Shift function

! Note that remaining function never can be shifted in Program 1.
(For AQ80 see 9.3.4 and for TX52/55 9.4.4)

Program Option 1 - Shift function				
Supply line terminal	Connector	Function		Cable part
		8B	12B/12BD	
VDD3 Cable part:	OUT0	-	Button 1	
	OUT1	-	Button 2	
	OUT2	-	Button 3	
	OUT3	-	Button 4	
VDD4 Cable part:	OUT4	Button 1	Button 5	
	OUT5	Button 2	Button 6	
	OUT6	Button 3	Button 7	
	OUT7	Button 4	Button 8	
VDD5 Cable part:	OUT8	Button 5	Button 9	
	OUT9	Button 6	Button 10	
	OUT10	Button 7	Button 11	
		SHIFT (Button 8)	SHIFT (Button 12)	
VDD6 Cable part:	OUT12	-	Button 1 + SHIFT	
	OUT13	-	Button 2 + SHIFT	
	OUT14	-	Button 3 + SHIFT	
	OUT15	-	Button 4 + SHIFT	
VDD7 Cable part:	OUT16	Button 1 + SHIFT	Button 5 + SHIFT	
	OUT17	Button 2 + SHIFT	Button 6 + SHIFT	
	OUT18	Button 3 + SHIFT	Button 7 + SHIFT	
	OUT19	Button 4 + SHIFT	Button 8 + SHIFT	
VDD8 Cable part:	OUT20	Button 5 + SHIFT	Button 9 + SHIFT	
	OUT21	Button 6 + SHIFT	Button 10 + SHIFT	
	OUT22	Button 7 + SHIFT	Button 11 + SHIFT	
	OUT23	Activation output	Activation output	
VDD1 Cable part:	RCSS 1	RCSS 1		
VDD2 Cable part:	RCSS 2	RCSS 2		
Cable part:	+ 24VDC	+ 24VDC		
Cable part:	0VDC	0VDC		

7.1.3 Program Option 2 - Interlocking between the button pair

! Note that the interlock does not apply to remaining function
 (For AQ80 see 9.3.4 and for TX52/55 9.4.4)

Program Option 2 - Interlocking between the button pair				
Supply line terminal	Connector	Function		Cable part
		8B	12B/12BD	
VDD3 Cable part:	OUT0	-	Button 1	
	OUT1	-	Button 2	
	OUT2	-	Button 3	
	OUT3	-	Button 4	
VDD4 Cable part:	OUT4	Button 1	Button 5	
	OUT5	Button 2	Button 6	
	OUT6	Button 3	Button 7	
	OUT7	Button 4	Button 8	
VDD5 Cable part:	OUT8	Button 5	Button 9	
	OUT9	Button 6	Button 10	
	OUT10	Button 7	Button 11	
	OUT11	Button 8	Button 12	
VDD8 Cable part:	OUT23	Activation output	Activation output	
VDD1 Cable part:	RCSS 1	RCSS 1		
VDD2 Cable part:	RCSS 2	RCSS 2		
Cable part:	+ 24VDC	+ 24VDC		
Cable part:	0VDC	0VDC		

B1	interlocked with	B2
B3	interlocked with	B4
B5	interlocked with	B6
B7	interlocked with	B8
B9	interlocked with	B10
B11	interlocked with	B12

7.1.4 Program Option 3 - Interlocking between the button pair, Shift function

- ! Note that the interlock does not apply to remaining movements
(For AQ80 see 9.3.4 and for TX52/55 9.4.4)
- ! Note that remaining function never can be shifted in Program 3.
(For AQ80 see 9.3.4 and for TX52/55 9.4.4)

Program Option 3 - Interlocking between the button pair, Shift function				
Supply line terminal	Connector	Function		Cable part
		8B	12B/12BD	
VDD3 Cable part:	OUT0	-	Button 1	
	OUT1	-	Button 2	
	OUT2	-	Button 3	
	OUT3	-	Button 4	
VDD4 Cable part:	OUT4	Button 1	Button 5	
	OUT5	Button 2	Button 6	
	OUT6	Button 3	Button 7	
	OUT7	Button 4	Button 8	
VDD5 Cable part:	OUT8	Button 5	Button 9	
	OUT9	Button 6	Button 10	
	OUT10	Button 7	Button 11	
		SHIFT (Button 8)	SHIFT (Button 12)	
VDD6 Cable part:	OUT12	-	Button 1 + SHIFT	
	OUT13	-	Button 2 + SHIFT	
	OUT14	-	Button 3 + SHIFT	
	OUT15	-	Button 4 + SHIFT	
VDD7 Cable part:	OUT16	Button 1 + SHIFT	Button 5 + SHIFT	
	OUT17	Button 2 + SHIFT	Button 6 + SHIFT	
	OUT18	Button 3 + SHIFT	Button 7 + SHIFT	
	OUT19	Button 4 + SHIFT	Button 8 + SHIFT	
VDD8 Cable part:	OUT20	Button 5 + SHIFT	Button 9 + SHIFT	
	OUT21	Button 6 + SHIFT	Button 10 + SHIFT	
	OUT22	Button 7 + SHIFT	Button 11 + SHIFT	
	OUT23	Activation output	Activation output	
VDD1 Cable part:	RCSS 1	RCSS 1		
VDD2 Cable part:	RCSS 2	RCSS 2		
Cable part:	+ 24VDC	+ 24VDC		
Cable part:	0VDC	0VDC		

AQ80		
B1	interlocked with	B2
B3	interlocked with	B4
B5	interlocked with	B6

TX52/55		
B1	interlocked with	B2
B3	interlocked with	B4
B5	interlocked with	B6
B7	interlocked with	B8
B9	interlocked with	B10

7.1.5 Program Option 4 - Interlocking between the button pair, High speed

- ! Note that the interlock does not apply to remaining movements
(For AQ80 see 9.3.4 and for TX52/55 9.4.4)
- ! Note that remaining function never can be in highspeed in Program 4.
(For AQ80 see 9.3.4 and for TX52/55 9.4.4)

Program Option 4 - Interlocking between the button pair, Highspeed				
Supply line terminal	Connector	Function		Cable part
		8B	12B/12BD	
VDD3 Cable part:	OUT0	-	Button 1	
	OUT1	-	Button 2	
	OUT2	-	Button 3	
	OUT3	-	Button 4	
VDD4 Cable part:	OUT4	Button 1	Button 5	
	OUT5	Button 2	Button 6	
	OUT6	Button 3	Button 7	
	OUT7	Button 4	Button 8	
VDD5 Cable part:	OUT8	Button 5	Button 9	
	OUT9	Button 6	Button 10	
	OUT10	Button 7	Button 11	
		SHIFT (Button 8)	SHIFT (Button 12)	
VDD6 Cable part:	OUT12	-	Button 1 + SHIFT	
	OUT13	-	Button 2 + SHIFT	
	OUT14	-	Button 3 + SHIFT	
	OUT15	-	Button 4 + SHIFT	
VDD7 Cable part:	OUT16	Button 1 + SHIFT	Button 5 + SHIFT	
	OUT17	Button 2 + SHIFT	Button 6 + SHIFT	
	OUT18	Button 3 + SHIFT	Button 7 + SHIFT	
	OUT19	Button 4 + SHIFT	Button 8 + SHIFT	
VDD8 Cable part:	OUT20	Button 5 + SHIFT	Button 9 + SHIFT	
	OUT21	Button 6 + SHIFT	Button 10 + SHIFT	
	OUT22	Highspeed	Highspeed	
	OUT23	Activation output	Activation output	
VDD1 Cable part:	RCSS 1	RCSS 1		
VDD2 Cable part:	RCSS 2	RCSS 2		
Cable part:	+ 24VDC	+ 24VDC		
Cable part:	0VDC	0VDC		

AQ80		
B1	interlocked with	B2
B3	interlocked with	B4
B5	interlocked with	B6

TX52/55		
B1	interlocked with	B2
B3	interlocked with	B4
B5	interlocked with	B6
B7	interlocked with	B8
B9	interlocked with	B10

Highspeed	
Step 2 for all buttons activate OUT22 highspeed	

7.1.6 Program Option 5 - Interlocking between the button pair, separate high speed

! Note that the interlock does not apply to remaining movements
(For AQ80 see 9.3.4 and for TX52/55 9.4.4)

Program Option 5 - Interlocking between the button pair, separate highspeed				
Supply line terminal	Connector	Function		Cable part
		8B	12B/12BD	
VDD3 Cable part:	OUT1	Button 1, 1 st & 2 nd	Button 5, 1 st & 2 nd	
	OUT2	Button 1, 2 nd	Button 5, 2 nd	
	OUT3	Button 2, 1 st & 2 nd	Button 6, 1 st & 2 nd	
VDD4 Cable part:	OUT4	Button 2, 2 nd	Button 6, 2 nd	
	OUT5	Button 3, 1 st & 2 nd	Button 7, 1 st & 2 nd	
	OUT6	Button 3, 2 nd	Button 7, 2 nd	
VDD5 Cable part:	OUT7	Button 4, 1 st & 2 nd	Button 8, 1 st & 2 nd	
	OUT8	Button 4, 2 nd	Button 8, 2 nd	
	OUT9	Button 5, 1 st & 2 nd	Button 9, 1 st & 2 nd	
VDD6 Cable part:	OUT10	Button 5, 2 nd	Button 9, 2 nd	
	OUT11	Button 6, 1 st & 2 nd	Button 10, 1 st & 2 nd	
	OUT12	Button 6, 2 nd	Button 10, 2 nd	
VDD7 Cable part:	OUT13	Button 7, 1 st & 2 nd	Button 11, 1 st & 2 nd	
	OUT14	Button 7, 2 nd /REM	Button 11, 2 nd /REM	
	OUT15	Button 1-6, 1 st & 2 nd	Button 5-10, 1 st & 2 nd	
VDD1 Cable part:	OUT16	Button 8, 1 st /REM	Button 12, 1 st /REM	
VDD2 Cable part:	RCSS 1	RCSS 1		
Cable part:	RCSS 2	RCSS 2		
Cable part:	+ 24VDC	+ 24VDC		
Cable part:	0VDC	0VDC		

Explanation	
1 st	= Button first step
2 nd	= Button second step
REM	= Button remaining
B8 remaining disable 2nd step for B1-B6 (Micro), on Era 8B with display	

AQ80		
B1	interlocked with	B2
B3	interlocked with	B4
B5	interlocked with	B6

TX52/55		
B5	interlocked with	B6
B7	interlocked with	B8
B9	interlocked with	B10

8 Derating

The maximum possible total output current of the T-Rx 500 receiver is more than 30 A. As the internal switch losses in the receiver generates heat the maximum output current can not be used over the whole specified temperature range.

8.1 Convection cooling

If a T-Rx 500 receiver is located in free, quasi-stationary air (convection cooling) the maximum allowed output current must be reduced according to Figure 10.

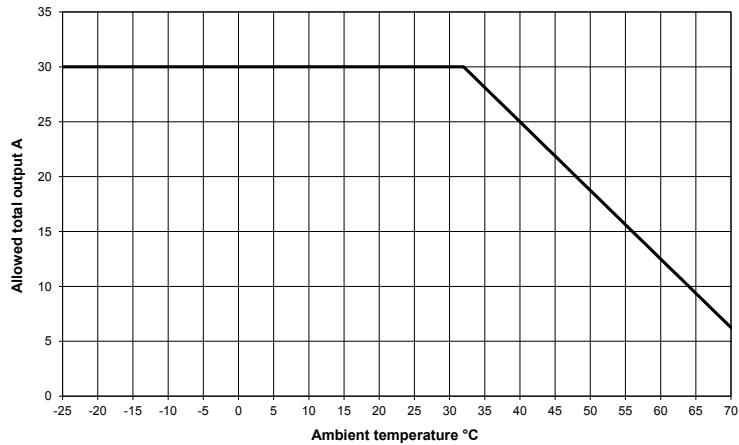

Figure 10. Convection cooling. Maximum allowed output current versus ambient temperature

9 Commissioning

9.1 *Frequency setting*

The radio transmission used in the T-Rx Std. systems can use either a frequency hopping transmission scheme or scan mode where frequency are automatically selected. The default factory setting is frequency hopping which is recommended for most applications.

Note! The transmitter and receiver must have the same frequency setting.

Frequency hopping

Frequency band 400 uses frequency hopping transmission.

When frequency hopping is selected, the frequency changes automatically between 15 different frequencies in the frequency-band.

Scan mode

Scan free frequency

Scan free frequency scheme automatically scans between 15 different frequencies and one frequency in the frequency-band will be used. The transmitter changes to a free frequency every time it's started, as long as the transmitter searches for a free frequency the status indicator glows yellow.

Fixed frequency

Fixed frequency channel set by the user. For Receiver see section 9.1.1, and for transmitter, see section 9.3.3 for AQ80 and section 9.4.3 for TX52/55.

9.1.1 Radio frequency setting in Receiver RXO

This setting is made in the RXO manager. Refer to 951538-000 Manager manual RXO.

9.2 Overview transmitters

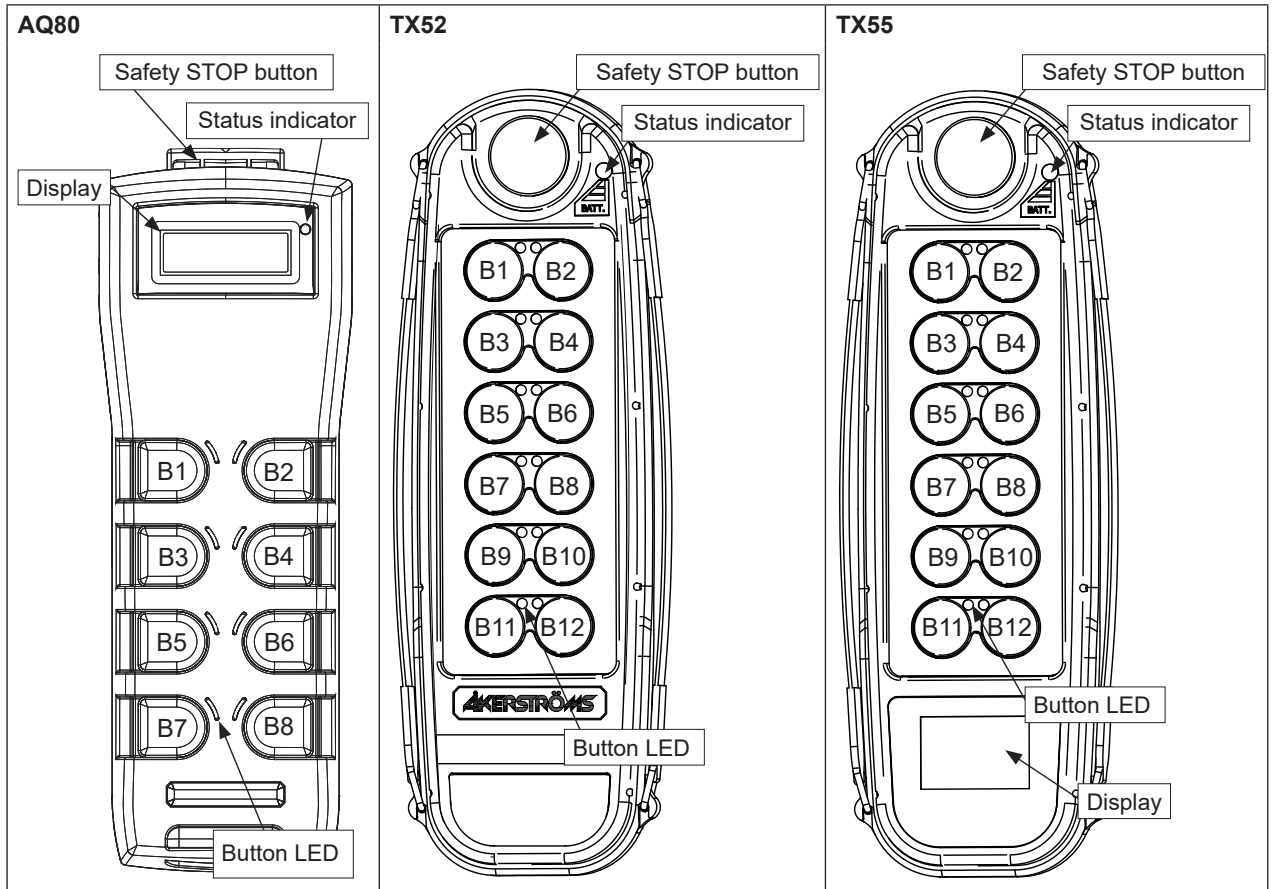

9.2.1 Place symbol label

Alongside the buttons there is room for a symbol label. A sheet of symbol labels are included with the delivery.

1. Before placing the label, clean the surface with alcohol (do not use isopropyl alcohol).
2. Place the label; make sure that the symbol label is placed at the right button!

Place for
symbol label

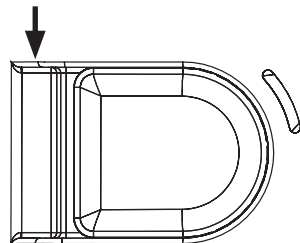

9.3 AQ80 Transmitter configuration mode

Enter configuration menu

Press button B8 (2nd step) while pulling up the safety stop button. Hold down the button 3 seconds until the status indicator glows yellow showing that the transmitter is in configuration mode.

Submenu

Browse submenu with the buttons B1 and B2. Choose submenu with button B8. To return to the main menu while you are in a submenu, press button B7.

Submenus:

- “Shutdown”
- “PIN-code”
- “Frequency”
 - “433 MHz”
- “Button function”
- “Radio comm power”
- “FX sequence”
- “System info”

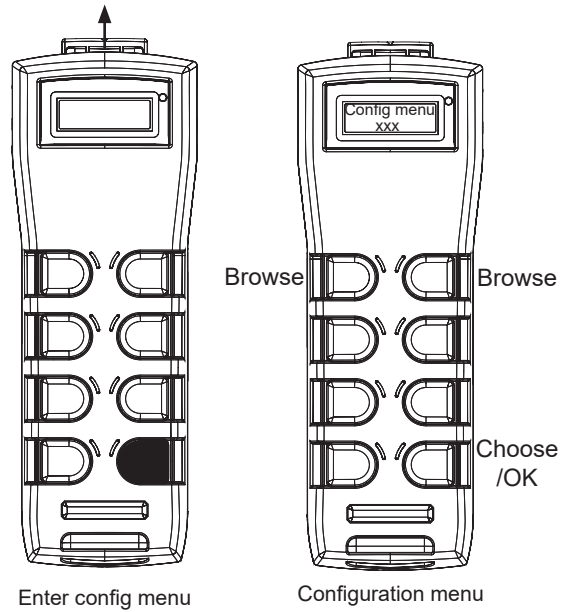

Exit/Save

Finish by turning the transmitter off by pushing the safety stop button down. This also saves the changes that have been made.

9.3.1 Shutdown Time of the Transmitter

The transmitter shuts down automatically if not used for a certain amount of time. This time can be adjusted in the transmitter configuration menu.

1. Enter the configuration menu.
2. Then select “Shutdown” with B8 (browse with B1 and B2).
3. Then browse the desired shutdown time with B1 and B2:
 - “2 minutes”
 - “5 minutes”
 - “15 minutes”
 - “no shutdown”

Already selected shutdown time is indicated by button LED B1.

4. Select shutdown time by press down button B8.
5. Automatic return to the main menu or restart the transmitter.

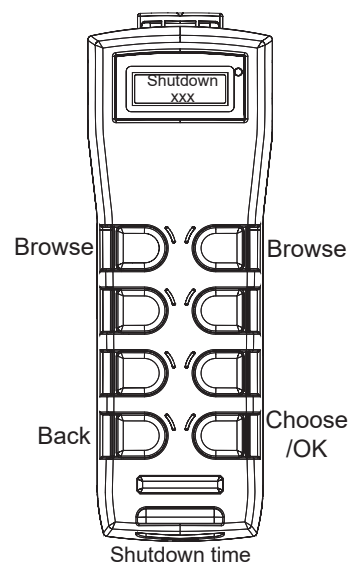

9.3.2 PIN-code Configuration of the Transmitter

The transmitter is equipped with a user configurable PIN-lock to prevent unauthorized access to the system. The PIN-lock is disabled by default.

1. Enter the configuration menu.
2. Then select “PIN-code” with B8 (browse with B1 and B2).
3. Enter PIN:
For **enable** enter the factory setting 3333 and for **disable** enter the old PIN-code.
Press B1 repeatedly to select number and B8 to choose the number. Delete a number with B2.
4. Enter new PIN:
Enter the new 4-digit PIN.
For **enable** enter the new PIN (not 3333) and for **disable** enter the factory setting 3333.
5. Repeat PIN:
Repeat the PIN code.
6. Automatic return to the main menu or restart the transmitter.

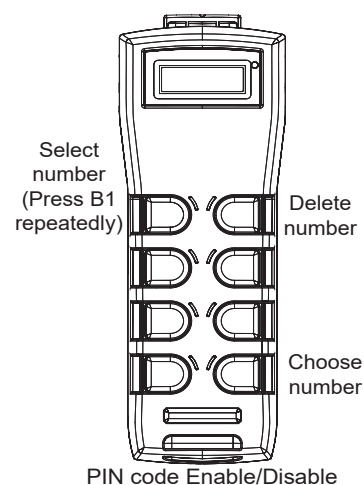

9.3.2.1 Entering PIN-code at start-up

When PIN is enabled the transmitter will not start to transmit before the correct PIN-code is entered. If the transmitter is PIN locked at startup status indicator shows red continuous light. Display will show “Enter PIN”.

Enter the 4-digit PIN-code by press B1 repeatedly to select number and B8 to choose the number. Delete a number with B2. When all 4-digit are selected, press B8 once again to select the PIN code.

At successful login the status indicator shows green flashing. Display shows “PIN OK!”. The unit is now in operating mode.

9.3.3 Radio Frequency Setting in the AQ80 Transmitter

To change the settings do the following:

1. Enter the configuration menu.
2. Then select “Frequency” with B8 (browse with B1 and B2).
3. Then browse to the desired setting with B1 and B2.
 - “Frequency hopping”
 - “Scan mode”
 - “Channel 0-XX”

Already selected setting is shown when entering the frequency setting menu.
4. Select setting by press down button B8.
5. Automatic return to the main menu or restart the transmitter.

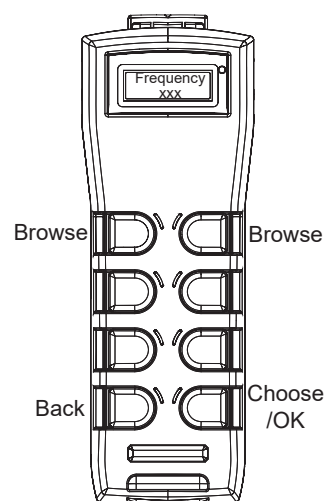

- **Frequency hopping:** When frequency hopping is selected, the frequency changes automatically between different frequencies in the frequency-band.
- **Scan Mode:** Automatically scans between different frequencies and one frequency in the frequency-band will be used. The transmitter changes to a free frequency every time it's started, the scan will start at the same frequency that was used last time the transmitter was started.
- **Channel:** Sets a specific channel.
See “9.3.3.2 Fixed frequency” on page 27.

9.3.3.1 433 MHz (only frequency band 400)

In frequency band 400 there is an opportunity to select region.

1. Enter the configuration menu.
2. Then select “433 MHz” with B8 (browse with B1 and B2).
3. Then browse to the desired setting with B1 and B2.
 - “EU”
 - “Other”

Already selected setting is indicated by button LED B1.

4. Select setting by press down button B8.
5. Automatic return to the main menu or restart the transmitter.

- ! **Note. If the equipment is being operated in EU-region this setting has to be set to EU for correct fulfill the regulation! See “Appendix 1 - European Radio Regulation” on page 37.**
- ! **For Other make sure to fulfill any rules or regulations or any applicable local, state, or federal governing laws.**

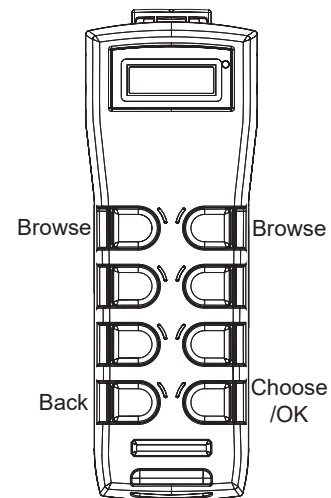

9.3.3.2 Fixed frequency

Channel no	434MHz EU	433-434MHz Extended
0	434,05	433,3
1	434,075	433,325
2	434,1	433,35
3	434,125	433,375
4	434,15	433,4
5	434,175	433,425
6	434,2	433,45
7	434,225	433,475
8	434,25	433,5
9	434,275	433,525
10	434,3	433,55
11	434,325	433,575
12	434,35	433,6
13	434,375	433,625
14	434,4	433,65
15	434,425	433,675
16	434,45	433,7
17	434,475	433,725
18	434,5	433,75
19	434,525	433,775
20	434,55	433,8
21	434,575	433,825
22	434,6	433,85
23	434,625	433,875
24	434,65	433,9
25	434,675	433,925
26	434,7	433,95
27	434,725	433,975
28	434,75	434
29	434,775	434,025
30		434,05
31		434,075
32		434,1
33		434,125
34		434,15
35		434,175
36		434,2
37		434,225
38		434,25
39		434,275
40		434,3
41		434,325
42		434,35
43		434,375
44		434,4
45		434,425
46		434,45
47		434,475
48		434,5
49		434,525
50		434,55
51		434,575
52		434,6
53		434,625
54		434,65
55		434,675
56		434,7
57		434,725
58		434,75
59		434,775

Table 2. Fixed frequency list

9.3.4 Adjustment of the Push Buttons Remaining and Momentary Functions

The buttons either have momentary functions, which give a signal for only as long as you keep pressing, or remaining functions.



Note that this function needs support from the receiver PLC. Before changing these parameters, check the program options. Only qualified personnel may make these changes.

1. Enter the configuration menu.
2. Then select “Button function” with B8 (browse with B1 and B2).
3. Press down the buttons for which you want to have a remaining/momentary function. Lighted button LED indicates remaining function. **Note:** The three pair of buttons 1-2, 3-4 and 5-6 must have the same settings within the pair. Otherwise the momentary function is disabled on the button that is not remaining.
4. Restart the transmitter.

9.3.5 Radio communication power

To change the settings do the following:

1. Enter the configuration menu.
2. Then select “Radio comm power” with B8 (browse with B1 and B2).
3. Then browse to the desired setting with B1 and B2.
 - “Auto power”
 - “100 % power”
 - “25 % power”

Already selected setting is indicated by button LED B1.

4. Select setting by press down button B8.
5. Automatic return to the main menu or restart the transmitter.

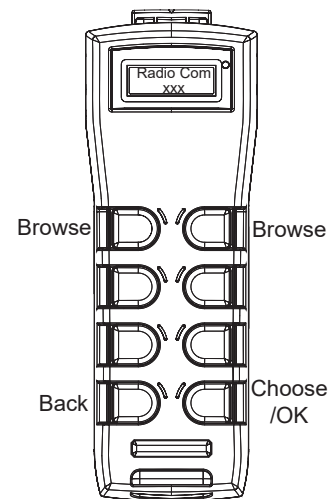

9.3.6 FX sequence

To change the settings do the following:

1. Enter the configuration menu.
2. Then select “FX sequence” with B8 (browse with B1 and B2).
3. Then browse to the desired setting with B1 and B2.
 - “255 X:XX Disabled”
 - “000 0:0 - 119 7:14”

Already selected setting is the first one that comes up when entering the menu.

4. Select setting by press down button B8.
5. Automatic return to the main menu or restart the transmitter.

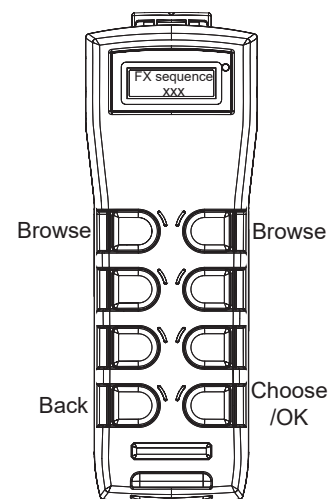

9.3.7 System info

Shows firmware version for the CIM card, ID number and package rate. Press any of the two bottom buttons for exit this menu.

9.4 TX52/55 Transmitter configuration

9.4.1 Shutdown time

The transmitter shuts down automatically if not used for a certain amount of time. This time can be adjusted using the buttons on the transmitters.

1. Press button 11 (step 2) and button 7 while releasing the safety stop button. Hold the buttons for 3 seconds until the status indicator glows yellow (shall change from green to yellow) showing that the transmitter is in setup-mode. The display shows “Auto-Off Config” showing that the transmitter is in setup-mode.
2. Then select shutdown time by pressing button for the selected mode.
 - Button 5 = 2 min
 - Button 6 = 5 min
 - Button 7 = 15 min
 - Button 8 = no shutdown
3. A green LED indicates which button has been selected.
4. Restart the transmitter.

9.4.2 PIN Configuration

The transmitter is equipped with a user configurable PIN-lock to prevent unauthorized access to the system. The PIN-lock is disabled by default.

9.4.2.1 Enable PIN

1. Press button B11 (step 2) and button B8 while releasing the safety stop button. Hold the buttons for 3 seconds until the status indicator indicates configuration mode. When entering this mode LED L1 and L2 will be lit. The display shows “Enter PIN”.
2. Enter the factory setting 3333 with the buttons B1-B8.
3. If PIN ok LED L1, L2 and L3 will be lit. Display shows “PIN OK!” “Enter new PIN”. Enter the new 4-digit PIN with the buttons B1-B8. Do not use the code 3333.
4. During this step LED L1, L2, L3 and L4 will be lit. Display shows “Repeat new PIN” Repeat new 4-digit PIN. Display shows “PIN set OK!” if successful.
5. If PIN set OK L5 will be lit. Display shows “Restart unit”. Restart the transmitter to activate the new setting.

9.4.2.2 Disable PIN

Repeat the above procedure (section “9.4.2.1 Enable PIN”). Enter the old PIN and 3333 as the new PIN (factory setting). Restart the transmitter to activate the new setting.

9.4.2.3 Entering PIN at start-up

When PIN is enabled the transmitter will not start to transmit before the correct PIN code is entered.

Indications when PIN-locked: L1 and L2 will be lit and the status indicator will be steady RED. Display will show “Enter PIN”.

Enter the 4-digit PIN with the buttons B1-B8. Display shows “PIN OK!” at successful login.

B1=	1
B2=	2
B3=	3
B4=	4
B5=	5
B6=	6
B7=	7
B8=	8

9.4.3 Radio Frequency Setting in the TX52/55 Transmitter

To change the settings do the following:

1. Press button 10 (step 2) and button 11 while pulling up the safety stop button. Hold down the buttons in 3 seconds until the status indicator glows yellow (shall change from green to yellow) showing that the transmitter is in setup-mode. The display also show information during this setting.
2. Set all buttons to OFF (○) for frequency hopping or to ON (●) for scan mode, button ON is indicated by the button LED glowing green. See Table 3 for fixed frequency setting.

! Note all other combinations except in this table are reserved

3. Finish by turning the transmitter off by pushing the safety stop button down.

Channel no	B1	B2	B3	B4	B5	B6	B7	B8	
0	○	○	○	○	○	○	○	○	Frequency hopping
1	●	○	○	○	○	○	○	○	Fixed channel
2	○	●	○	○	○	○	○	○	
3	●	●	○	○	○	○	○	○	
4	○	○	●	○	○	○	○	○	
5	●	○	●	○	○	○	○	○	
6	○	●	●	○	○	○	○	○	
7	●	●	●	○	○	○	○	○	
8	○	○	○	●	○	○	○	○	
9	●	○	○	●	○	○	○	○	
10	○	●	○	●	○	○	○	○	
11	●	●	○	●	○	○	○	○	
12	○	○	●	●	○	○	○	○	
13	●	○	●	●	○	○	○	○	
14	○	●	●	●	○	○	○	○	
15	●	●	●	●	○	○	○	○	
16	○	○	○	○	●	○	○	○	
17	●	○	○	○	●	○	○	○	
18	○	●	○	○	●	○	○	○	
19	●	●	○	○	●	○	○	○	
20	○	○	●	○	●	○	○	○	
21	●	○	●	○	●	○	○	○	
22	○	●	●	○	●	○	○	○	
23	●	●	●	○	●	○	○	○	
24	○	○	○	●	●	○	○	○	
25	●	○	○	●	●	○	○	○	
26	○	●	○	●	●	○	○	○	
27	●	●	○	●	●	○	○	○	
28	○	○	●	●	●	○	○	○	
29	●	○	●	●	●	○	○	○	
255	●	●	●	●	●	●	●	●	Scan mode

Table 3. Frequency setting list for TX52/55

9.4.4 Adjustment of the push button functions

The buttons either have momentary functions, which give a signal for only as long as you keep pressing, or a remaining function. The button LED indicates an active remaining function.

1. Press button 11 (step 2) and button 9 while releasing the safety stop button. Hold down the buttons in 3 sec. until the status indicator glows yellow (shall change from green to yellow) showing that the transmitter is in setup-mode. The display shows “Button Config” showing that the transmitter is in setup-mode.
2. Then press down the buttons for which you want to have a remaining function and the LEDs next to the buttons will light up.
3. Restart the transmitter.

9.5 Pairing of transmitter and receiver

Status indicator LED 5 and the pairing push button (see Figure 5) on the MAIN board should be used when pairing the receiver and transmitter.

1. Open the service hatch on the receiver. Press the pairing button in the receiver.

Set the transmitter in pairing mode.

AQ80: Hold down button B7 and B8 when starting the transmitter.
Continue to press the buttons for ≈5 seconds.

TX52/55: Hold down button B11 and B12 when starting the transmitter.
Continue to press the buttons for ≈5 seconds.

2. See pairing indications, next section. When paired LED 5 shows steady green. If this hasn't been indicated within 15 seconds restart the transmitter.
3. Restart the system to activate the new ID number.

The receiver has now learned the transmitter ID number and will only accept commands from that transmitter.

Enter pair mode AQ80

Enter pair mode TX52/55

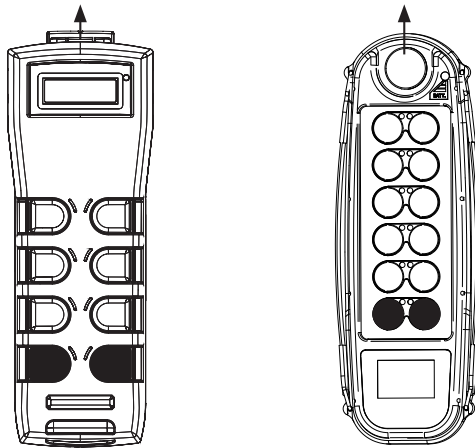

9.5.1 Pairing indications

Mode	Event	Status indicator receiver	Flash rate
Pairing	In pairing mode	Green/yellow	50/50 ms
	Paired	Steady green	

Table 4. Receiver pairing indication

Mode	Event	Status indicator transmitter	Flash rate
In pairing mode	Not paired	Green/yellow	50/50 ms
	Paired	Steady green	

Table 5. Transmitter pairing indication

Pairing:	Pairing ready:	Link timeout:
<div style="border: 1px solid black; padding: 5px; text-align: center;"> Pair mode Pairing... </div>	<div style="border: 1px solid black; padding: 5px; text-align: center;"> Pair mode Paired! </div> <p style="text-align: center;">↓</p> <div style="border: 1px solid black; padding: 5px; text-align: center;"> Restart System! </div>	<div style="border: 1px solid black; padding: 5px; text-align: center;"> Pair mode Failed! </div> <p style="text-align: center;">↓</p> <div style="border: 1px solid black; padding: 5px; text-align: center;"> Restart Pair mode! </div>

Table 6. Transmitter display pairing indication

9.6 CIM Card

The CIM card is used for storing configuration information. You can take out the CIM-module from one system and place it in a spare transmitter with the same system program and it will work exactly* the same.



This exchange has to be done in a clean, dry and ESD safe environment.

- ! To avoid personal and/or damages on property; exchange CIM card ONLY when the transmitter battery has been removed.
- ! *Note that some settings do not follow with the AQ80 CIM card and need to be set in the "spare" transmitter. These settings are; Radio comm power, FX sequence 0-119.

9.6.1 Removing/Mounting CIM Card AQ80

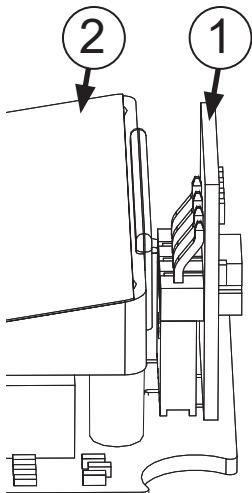

1. To disassemble the transmitter, remove the battery, unscrew the six screws* holding the back cover of the transmitter, pull up the back of the transmitter carefully and pull out the connector for the battery and remove the back enclosure entirely.
*Note that the screw below the battery is underneath the type label. Make a little cut on the type label around the screw; so not the entire type label is damage when removing the screw.
2. The CIM card ① is located at the top of the transmitter above the display board ②. Gently remove the CIM card straight up.
3. Install the CIM card primarily in the original transmitter, alternative spare transmitter. Be sure to insert the CIM card properly in its connector.
4. Reinstall the enclosure. The screws should be tightened with $0.35\text{Nm} \pm 0.05$.
5. Insert battery. Now, the transmitter is ready for operation.

9.6.2 Removing/Mounting CIM Card TX52/55

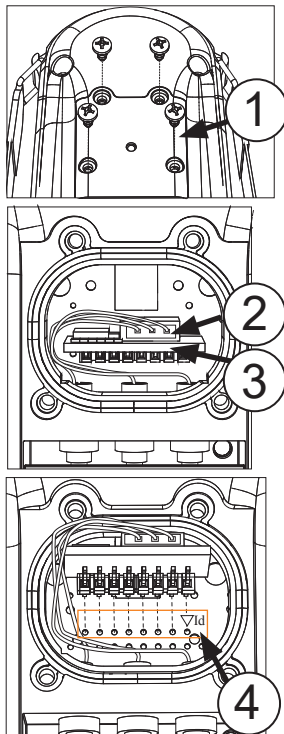

1. Remove the battery. Unscrew the CIM card cover ①, 4 screws.
2. Gently remove the CIM card ③ straight up.
3. Pull out the 3-pole CIM card power supply ②.
4. Install primarily original CIM card, alternative exchange CIM card. Be sure to insert the CIM card in its connector, the upper row of holes, see labeling Key-Id ④.
5. Mount the power supply connector (note that the connection cables must be placed beside the CIM card).
6. Reinstall CIM card cover. The screws should be tightened with 1 Nm.
7. Insert battery. Now, the transmitter is ready for operation.

10 Function tests

Before the following test is performed, make sure to prevent unintended movements of the controlled object from becoming a safety hazard.

Check that the transmitter can control the receiver by testing all functions and note if the output relays and the corresponding inputs on the controlled object are activated.

Follow the local safety regulations for the equipment and start the equipment as described in the Operator Manual.

Check the following:

- Are all movements correct?
- Do the other functions operate correctly?
- Does the stop function on the transmitter work properly?
- Also test the stop function by removing the battery in the transmitter.
- Is it possible to control the equipment from the normal controllers? If it is possible to operate the equipment from more than one controller at a time the system is incorrectly installed.
- There should be a changeover switch between radio/pendant controls to prevent control from two places at the same time.
- Test that all the safety and stop limits switches work.

This list of test is for reference only and can be extended by the system integrator in the specific installations and the corresponding risk analysis.

11 Indications

11.1 Receiver indications

Status indicator, see “Figure 4. Receiver back side”.

Mode	Event	Status LED	Flash rate
Status OK	Not connected	Fast GREEN	50/50 ms
	CONNECTED, RCSS=ON	Slow GREEN	30/970 ms
	CONNECTED, RCSS=OFF	Medium GREEN	50/250 ms
ERROR	Receiver internal error	Steady RED	
	Transmitter internal error	Fast RED	50/50 ms
	No supply power	Off	

Table 7. Indications on the Receiver back side

11.2 Transmitter indications

11.2.1 Status indicator

If the transmitter under start up (if not PIN locked) or operation detects a fault in any of the transmitters self-tests, the status indicator (see section 9.2) will indicate a continuous red light, after which the transmitter is shut down.

INDICATIONS	EXPLANATIONS
Green flashing	OK, normal operation
Yellow quick flashing	Battery voltage low <3.5 V
Yellow continuous, during operating	Battery empty. Transmitter will shut-off within 10s
Yellow continuous, at start-up	Configuration mode
Red continuous, at start-up	PIN locked
Red continuous, during operation	Hardware fault
Blue continuous, other indications may occur simultaneously	High power (only AQ80)

Table 8. Indications of the transmitter's status indicator

11.2.2 Display indications

These default symbols can appear on the display depending on the configuration. For configuration refer to Display control mapping RXO Std.

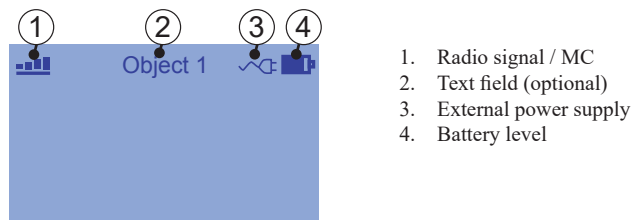

1. Radio signal / MC
2. Text field (optional)
3. External power supply
4. Battery level

11.2.2.1 Radio signal quality

No radio link established	Weak signal	Good signal	Strong signal	Very strong signal
	-

MC on is indicated by a line beneath the radio signal symbol, example

11.2.2.2 Text field (option)

This text is configured in the receiver (8 characters) using the RXO manager.

11.2.2.3 Battery level

Battery empty	25%	50%	75%	100% (fully charged)

12 Trouble shooting

On push button transmitter:

Ensure that a charged battery is inserted in the transmitter.

The status indicator indicates following:

- Slow green flashing means that the transmitter is fully operational
- Fast yellow flashing means that the battery needs charging
- Steady yellow light means that the transmitter is in configuration mode
- Steady red light at start up means that the transmitter is PIN locked
- Steady red light during operating means that an error in the transmitter has been discovered and it will shut itself down

In receiver:

- Check the indications of mode "ERROR, see Table 7 on page 34

Appendix 1 - European Radio Regulation

Exerpts from ERC RECOMMENDATION 70-03:

Frequency Band		Power / Magnetic Field	Spectrum access and mitigation requirement	Channel spacing	Notes
f	433.050-434.790 MHz (note 4)	10 mW e.r.p.	< 10 % duty cycle (note 1)	No spacing	
f1	433.050-434.790 MHz (note 4bis)	1 mW e.r.p. -13 dBm/10 kHz	No requirement	No spacing	Power density limited to -13 dBm/10 kHz for wideband modulation with a bandwidth greater than 250 kHz
f2	434.040-434.790 MHz (note 4bis)	10 mW e.r.p.	No requirement	Up to 25 kHz	
g	863-870 MHz (note 3, 4 and 6)	≤ 25 mW e.r.p.	≤ 0.1% duty cycle or LBT (note 1 and 5)	≤ 100 kHz for 47 or more channels (note 2)	FHSS modulation
		≤ 25 mW e.r.p. (note 6) Power density : - 4.5 dBm/100 kHz (note 7)	≤ 0.1% duty cycle or LBT+AFA (note 1, 5 and 6)	No spacing	DSSS and other wideband modulation other than FHSS
		≤ 25 mW e.r.p.	≤ 0.1% duty cycle or LBT+AFA (note 1 and 5)	≤ 100 kHz, for 1 or more channels modulation bandwidth ≤ 300 kHz (note 2)	Narrow /wide-band modulation
g1	868.000-868.600 MHz (note 4)	≤ 25 mW e.r.p.	≤ 1% duty cycle or LBT+AFA (note 1)	No spacing, for 1 or more channels (note 2)	Narrow / wide-band modulation. No channel spacing, however the whole stated frequency band may be used
g2	868.700-869.200 MHz (note 4)	≤ 25 mW e.r.p.	≤ 0.1% duty cycle or LBT+AFA (note 1)	No spacing, for 1 or more channels (note 2)	Narrow / wide-band modulation. No channel spacing, however the whole stated frequency band may be used
g3	869.400-869.650 MHz	≤ 500 mW e.r.p.	≤ 10% duty cycle or LBT+AFA (note 1)	25 kHz (for 1 or more channels)	Narrow / wide-band modulation The whole stated frequency band may be used as 1 channel for high speed data transmission
g4	869.700-870.000 MHz (note 4bis)	≤ 5 mW e.r.p.	No requirement	No spacing (for 1 or more channels)	Narrow / wide-band modulation. No channel spacing, however the whole stated frequency band may be used
		≤ 25 mW e.r.p.	up to 1% duty cycle or LBT+AFA (note 1)		

Note 1: When either a duty cycle, Listen Before Talk (LBT) or equivalent technique applies then it shall not be user dependent/adjustable and shall be guaranteed by appropriate technical means.
For LBT devices without Adaptive Frequency Agility (AFA), or equivalent techniques, the duty cycle limit applies. For any type of frequency agile device the duty cycle limit applies to the total transmission unless LBT or equivalent technique is used.

Note 2: The preferred channel spacing is 100 kHz allowing for a subdivision into 50 kHz or 25 kHz.

Note 4: Note 4: Audio and video applications are allowed provided that a digital modulation method is used with a max. bandwidth of 300 kHz.
Analogue and digital voice applications are allowed with a max. bandwidth ≤ 25 kHz.
In sub-band 863-865 MHz voice and audio conditions of Annexes 10 and 13 of ERC/REC 70 – 03 apply respectively.

Note 4bis: Audio and video applications are excluded. Analogue or digital voice applications are allowed with a max. bandwidth ≤ 25 kHz and with spectrum access technique such as LBT or equivalent. The transmitter shall include a power output sensor controlling the transmitter to a maximum transmit period of 1 minute for each transmission

Note 5: Duty cycle may be increased to 1% if the band is limited to 865-868 MHz.

Note 6: For other wide-band modulation than FHSS and DSSS with a bandwidth of 200 kHz to 3 MHz, duty cycle can be increased to 1% if the band is limited to 865-868 MHz and power to ≤10 mW e.r.p.



Åkerströms Björbo AB

Box 7, SE-785 21 Gagnef, Sweden

street Björbovägen 143

SE-785 45 Björbo, Sweden

Phone +46 241 250 00

Fax +46 241 232 99

E-mail sales@akerstroms.com

www.akerstroms.com

© Åkerströms Björbo AB, 2014

akerstroms.com