

Operating manual MC 704 V3



Fig. similar

Copyright clause

Translation, transfer to third parties as well as any duplication and distribution without our prior approval is prohibited.

Any infringement shall result in liability for damages. All rights are reserved, particularly with regard to the granting of patents or registration of utility models.

© Copyright by



Tel. +49-511-12 32 07-0

Fax +49-511-12 32 07-77

E-mail: info@ehb-electronics.de

Hans-Böckler-Str. 20
30851 Langenhagen
GERMANY

www.ehb-electronics.de

www.ehbshop.de

www.ehbservice.de

Table of contents

1	About these instructions	5
1.1	Target group.....	5
1.2	Use and safekeeping	5
1.3	Symbols and abbreviations	5
1.4	Presentation of information	6
2	Safety	7
2.1	General information on safety	7
2.2	Qualification of personnel.....	8
2.3	Intended use	8
3	Technical data	9
4	Software versions	10
4.1	Item no.: ehb 4315-I, ehb 4393-1F, ehb 4393-K, ehb 5495.....	11
4.2	Item no.: ehb 4752-3A, ehb 4752-I, ehb 5185-B	12
4.3	Item no.: ehb 4913-3B, ehb 5469, ehb 5474	13
4.4	Item no.: ehb 5321-A, ehb 5470, ehb 5475	14
4.5	Item no.: ehb 5467	15
4.6	Item no.: ehb 5084-E.....	16
4.7	Item no.: ehb 5468	17
4.8	Item no.: ehb 5182-D	18
4.9	Item no.: ehb 5130B, ehb 5132-B, ehb 5456.....	19
4.10	Item no.: ehb 5333-C, ehb 5471, ehb 5477	20
4.11	Item no.: ehb 5457, ehb 5472, ehb 5478	21
4.12	Item no.: ehb 5466, ehb 5473, ehb 5479	22
4.13	Item no.: ehb 4394-H, ehb 4318-G	23
4.14	Item no.: ehb 5536	24
5	Functional description	25
5.1	Operating and display elements	25
5.2	Self-test	25
5.3	Ignition switch.....	26
5.4	Starter protection function	26
5.5	Start optimisation	26
5.6	Pre-glowing function.....	26
5.7	Operating hours counter	27
5.8	Engine monitoring with fault shutdown	27
5.9	Cable start detection	27
6	Commissioning.....	28
6.1	Installation and connection information.....	28
6.2	Connection diagram diesel engines	31
6.3	Connection diagram gasoline engines.....	32
7	Operation.....	33
7.1	Status displays	33
7.2	Start engine	33
7.3	Stop engine	33
8	Troubleshooting.....	34
8.1	Fault detection.....	34
8.2	External stop / fault acknowledgement	34
8.3	Troubleshooting	35

9	Decommissioning	36
9.1	Disposal.....	36
10	Maintenance	37
10.1	Maintenance of the MC 704 V3.....	37
10.2	Repair.....	37
11	Index.....	38
12	Documentation information and history.....	39

1 About these instructions

1.1 Target group

Operator of the device

This documentation is intended for the operator of the device.

Information for service personnel

This documentation is also intended for service personnel who install the device and connect it to the engine.

NOTE

If your end customer carries out installation himself, please note that he should receive the edition of the operating manual.

1.2 Use and safekeeping

- Read and follow the operating manual before working on the device.
- Keep the operating manual in a clearly legible condition.
- The operating manual must be provided when the device is resold.

1.3 Symbols and abbreviations

You can find the most important abbreviations from this operating manual below

Abbreviation	Description
LED	Light Emitting Diode
ETR	Energize To Run
ETS	Energize To Stop

Tab. 1: Abbreviations

Listings in handling instructions:

1. Step 1
2. Step 2
3. ...

Numbering in figures and legends:

- 1 Component 1
- 2 Component 2
- 3 ...

Item list for information without specific sequence:

- Information
- Information
- ...

1.4 Presentation of information

ATTENTION

The signal word **ATTENTION** identifies possible material damage. Non-observance can cause damage to the machine.



Note concerning environmental protection

The signal word **Note concerning environmental protection** identifies information on environmental protection.

NOTE

The signal word **NOTE** identifies additional information about the device or its accessories.



Internal reference:

The internal reference identifies references to further information within the document.



External reference:

The external reference identifies references to external documents in which optional further information can be found.

2 Safety

2.1 General information on safety

Use	<p>This device is to be operated only in combination with the supplied accessories.</p> <p>Use only mild cleaning agents.</p> <p>Do not insert any objects into the device openings not intended for this purpose, since otherwise electronic faults can result.</p> <p>When operating the device, comply with the general accident prevention regulations.</p> <p>Do not operate the MC 704 V3 within range of strong electromagnetic fields.</p> <p>Note and comply with the temperature specifications given in the “Technical Data” chapter.</p>
Storage	<p>A decommissioned MC 704 V3 must be stored under the conditions specified.</p>
Installation	<p>Observe the notes of the manufacturer of the plugs and cable harnesses when installing the device.</p>
Shipping	<p>The unit is to be shipped either in its original packaging or in suitable sturdy alternative packaging.</p> <p>Improper packaging is regarded as <i>negligence</i> and results in any claims for repair under guarantee being forfeited.</p>
Maintenance	<p>The MC 704 V3 requires no maintenance and no special upkeep over its entire service life.</p>
Opening the MC 704 V3	<p>The MC 704 V3 does not contain any parts that can be serviced, replaced or repaired by the end customer.</p> <p>Please note that any unauthorised opening of the device will lead to the loss of warranty.</p>

ATTENTION



Never use a high-pressure cleaner to clean the device.

It has to be clearly communicated to personnel that high-pressure cleaning will lead to damage and result in the guarantee being rendered null and void.

2.2 Qualification of personnel

Only qualified and trained personnel may connect or install the device. The personnel must have the following qualifications:

- Special knowledge and experience of handling electrical equipment.
- Instruction and operating authorisation from the person responsible for safety.
- Knowledge of relevant standards, regulations, accident prevention regulations and operating conditions for safe application.

NOTE

- Always carry out work on the device according to the existing specifications and legal provisions.
 - The legal provisions are different depending on the operation site.
 - The operator must ensure that applicable laws are complied with.
-

2.3 Intended use

The device is only intended for installation in systems and vehicles driven by combustion engines. Together with the ignition key, it is used to start the combustion engine and monitor various typical characteristic values. This also applies for all accessories and parts that are included in the scope of delivery in conjunction with the technical specification. Here the technical data and specifications concerning the permitted use (installation, connection and operating conditions) are particularly authoritative.

Intended use also includes observing the operating manual.

3 Technical data

Parameter/Pin	Conditions	Values/Feature			Comments
		Min.	Typ	Max.	
Supply voltage UB with diesel engines		6 V	12 – 24V	36V	successfully tested with 4 – 40V
Supply voltage UB with gasoline engines		8V	12 – 16V	14V	
Interference voltage on UB	6Vss, 50Hz	14V		28V	
Voltage peaks on UB	2ms		200V		
Current consumption of the electronics for UB 8 - 24V terminal 30	Terminal 15 off Terminal 15 on* *Sleep mode		approx. 1mA approx. 12mA	200mA	The current consumption can increase depending on the connection of the inputs and outputs.
Digital outputs active high OUT3 fuel pump/sensor coil Pin 6 Operating magnet Pin 7 Pre-glowing/Alarm Pin 2 D+ excitation	Amb. temp.: 25°C			20A 3A 3A 0.5A	Short-circuit-proof
Digital inputs active low Pin 1 Oil pressure Pin 2 D+ Pin 3 Temperature Pin 4 Diverse Pin 9 External Stop	Amb. temp.: 25°C		< 50% of UB < 50% of UB < 50% of UB < 50% of UB < 1.3V		Low level detection
Digital inputs active high	Amb. temp.: 25°C		>4V UB/2		Terminal 15 Terminal 50
Operating temperature		-40°C		+85°C	
Storage temperature		-50°C		+85°C	
Humidity (non-condensing)	48h		95%		
Vibration	0 – 50Hz		5g		
Shock	15x, 10ms (half sine wave)		50g		
Dimensions	LxWxH	approx. 125x72.5x72.5mm			with ehb housing, without accessories

Weight		approx. 490g	without accessories
Fastening	Installation opening Screw points for shock mounts	66x66mm 45mm distance	
Degree of protection	Protected against dust, splash water	IP54	horizontal alignment

Tab. 2: Technical data

The product was tested according to the following standards:

- Emitted interference. Measurement of the noise radiation according to DIN EN 61000-6-4, DIN EN 61000-4-20
- Electrostatic discharge (ESD) immunity according to DIN EN 61000-4-2
- Radiated, radio-frequency, electromagnetic field immunity according to DIN EN 61000-4-3, DIN EN 61000-4-20, ISO 11451-1
- Electrical fast transient/burst immunity according to DIN EN 61000-4-4
- Surge immunity (surges) according to DIN EN 61000-4-5
- Immunity to conducted disturbances, induced by radio-frequency fields according to DIN EN 61000-4-6

Vibration according to DIN EN 60068-2-6

4 Software versions

MC 704 V3 is available in different software versions.

The version supplied can be read on the type plate (item no.)

The type plate is on the rear of the device.

Example:



Fig. 1: Example item no.

4.1 Item no.: ehb 4315-I, ehb 4393-1F, ehb 4393-K, ehb 5495

Software no.	S02359
Item no.:	ehb 4315-I ehb 4393-1F ehb 4393-K ehb 5495
Pin 6, Output 1 (3A)	ETR-HC 12s
Pin 7, Output 2 (3A)	ALARM SIGNAL
X105, Output 3 (20A)	ETR-HC 12s
Pin 1, Oil pressure	stopping, NC
Pin 2, Alternator D+	stopping, NC
Pin 3, Temperature	stopping, NO
Pin 4, Diverse	stopping, NO
Pin 8, Ext. Stop	stopping, NO
Excitation	with terminal 50 continuous excitation
Start delay	7s
Fault time	3s
ETR time without terminal 50	12s
Cable start detection	via oil and D+
PMT-3 expansion	No
Features	<ul style="list-style-type: none"> • Cable start • Continuous excitement at input D+

Tab. 3: Software data S02359

4.2 Item no.: ehb 4752-3A, ehb 4752-I, ehb 5185-B

Software no.	S02360
Item no.:	ehb 4752-3A ehb 4752-I ehb 5185-B
Pin 6, Output 1 (3A)	ETR-HC 12s
Pin 7, Output 2 (3A)	Vg10s Ng0s+50
X105, Output 3 (20A)	ETR-HC 12s
Pin 1, Oil pressure	stopping, NC
Pin 2, Alternator D+	stopping, NC
Pin 3, Temperature	stopping, NO
Pin 4, Diverse	No function
Pin 8, Ext. Stop	stopping, NO
Excitation	with terminal 50 continuous excitation
Start delay	7s
Fault time	3s
ETR time without terminal 50	12s after pre-glowing
Cable start detection	via oil and D+
PMT-3 expansion	No
Features	<ul style="list-style-type: none"> • Diverse LEDs as pre-glowing display • After-glowing only while terminal 50 is active • Pre-glowing is switched off with VG indicator • Cable start • Continuous excitement at D+

Tab. 4: Software data S02360

4.3 Item no.: ehb 4913-3B, ehb 5469, ehb 5474

Software no.	S02361
Item no.:	ehb 4913-3B ehb 5469 ehb 5474
Pin 6, Output 1 (3A)	ETR-HC 12s
Pin 7, Output 2 (3A)	Vg10s Ng3s without 50
X105, Output 3 (20A)	ETR-HC 12s
Pin 1, Oil pressure	stopping, NC
Pin 2, Alternator D+	stopping, NC
Pin 3, Temperature	stopping, NO
Pin 4, Diverse	No function
Pin 8, Ext. Stop	stopping, NO
Excitation	with terminal 50 continuous excitation
Start delay	7s
Fault time	3s
ETR time without terminal 50	12s
Cable start detection	via oil and D+
PMT-3 expansion	No
Features	<ul style="list-style-type: none"> • Diverse LEDs as pre-glowing display • No pre-glowing during start • Cable start • Continuous excitement at input D+

Tab. 5: Software data S02361

4.4 Item no.: ehb 5321-A, ehb 5470, ehb 5475

Software no.	S02362
Item no.:	ehb 5321-A ehb 5470 ehb 5475
Pin 6, Output 1 (3A)	ETR-HC 12s
Pin 7, Output 2 (3A)	ALARM SIGNAL
X105, Output 3 (20A)	ETR-HC 12s
Pin 1, Oil pressure	stopping, NC
Pin 2, Alternator D+	stopping, NC
Pin 3, Temperature	stopping, NO
Pin 4, Diverse	stopping, NC
Pin 8, Ext. Stop	stopping, NO
Excitation	with terminal 50 continuous excitation
Start delay	7s
Fault time	3s
ETR time without terminal 50	12s
Cable start detection	via oil and D+
PMT-3 expansion	No
Features	<ul style="list-style-type: none"> • Input Diverse responds inverted. This means, ground is not a fault, switch open or wire break is fault. • Cable start • Continuous excitement at input D+

Tab. 6: Software data S02362

4.5 Item no.: ehb 5467

Software no.	S02363
Item no.:	ehb 5467
Pin 6, Output 1 (3A)	ETR-HC 30s
Pin 7, Output 2 (3A)	ALARM SIGNAL
X105, Output 3 (20A)	ETR-HC 30s
Pin 1, Oil pressure	stopping, NC
Pin 2, Alternator D+	stopping, NC
Pin 3, Temperature	stopping, NO
Pin 4, Diverse	No function
Pin 8, Ext. Stop	PMT3 function
Excitation	with terminal 50 continuous excitation
Start delay	7s
Fault time	3s
ETR time without terminal 50	30s after pre-glowing
Cable start detection	via oil and D+
PMT-3 expansion	Yes
Features	<ul style="list-style-type: none"> • Diverse LEDs as pre-glowing display • State info of PMT-3 comes via input Pin 8 (Ext.Stop) • Cable start • Continuous excitement at input D+ <p>Functions with PMT-3 and software S02140:</p> <ul style="list-style-type: none"> • Temperature-dependent pre-glowing in PMT-3 hidden 2s with start and short-time pre-glowing interruption when engaging the starter. • PMT-3, X10 as external stop • Starter engagement protection

Tab. 7: Software data S02363

4.6 Item no.: ehb 5084-E

Software no.	S02364
Item no.:	ehb 5084-E
Pin 6, Output 1 (3A)	ETR-HC 30s
Pin 7, Output 2 (3A)	ALARM SIGNAL
X105, Output 3 (20A)	ETR-HC 30s
Pin 1, Oil pressure	stopping, NC
Pin 2, Alternator D+	stopping, NC
Pin 3, Temperature	stopping, NO
Pin 4, Diverse	stopping, NO
Pin 8, Ext. Stop	PMT3 function
Excitation	with terminal 50 continuous excitation
Start delay	7s
Fault time	3s
ETR time without terminal 50	30s after pre-glowing
Cable start detection	via oil and D+
PMT-3 expansion	Yes
Features	<ul style="list-style-type: none"> • Operating LED (flashing) as pre-glowing display • State info of PMT-3 comes via input Pin 8 (Ext.Stop) • Cable start • Continuous excitement at input D+ <p>Functions with PMT-3 and software S02140:</p> <ul style="list-style-type: none"> • Temperature-dependent pre-glowing in PMT-3 hidden 2s with start and short-time pre-glowing interruption when engaging the starter. • PMT-3, X10 as external stop • Starter engagement protection

Tab. 8: Software data S02364

4.7 Item no.: ehb 5468

Software no.	S02365
Item no.:	ehb 5468
Pin 6, Output 1 (3A)	ETR-HC 30s
Pin 7, Output 2 (3A)	ALARM SIGNAL
X105, Output 3 (20A)	ETR-HC 30s
Pin 1, Oil pressure	stopping, NC
Pin 2, Alternator D+	stopping, NC
Pin 3, Temperature	stopping, NO
Pin 4, Diverse	warning, NO
Pin 8, Ext. Stop	PMT3 function
Excitation	with terminal 50 continuous excitation
Start delay	7s
Fault time	3s
ETR time without terminal 50	30s after pre-glowing
Cable start detection	via oil and D+
PMT-3 expansion	Yes
Features	<ul style="list-style-type: none"> • Operating LED (flashing) as pre-glowing display • State info of PMT-3 comes via input Pin 8 (Ext.Stop) • Cable start • Continuous excitement at input D+ <p>Functions with PMT-3 and software S02135-2:</p> <ul style="list-style-type: none"> • Fixed 5s pre-glowing in PMT-3, hidden additional 2s. Without terminal 50 with 20s after-glowing. • PMT-3, X10 as external stop First time external stop alarm acknowledgement Second time external stop switches the engine off • Starter engagement protection

Tab. 9: Software data S02365

4.8 Item no.: ehb 5182-D

Software no.	S02366
Item no.:	ehb 5182-D
Pin 6, Output 1 (3A)	ETR-HC 30s
Pin 7, Output 2 (3A)	ALARM SIGNAL
X105, Output 3 (20A)	ETR-HC 30s
Pin 1, Oil pressure	stopping, NC
Pin 2, Alternator D+	stopping, NC
Pin 3, Temperature	warning, NO
Pin 4, Diverse	warning, NO
Pin 8, Ext. Stop	PMT3 function
Excitation	with terminal 50 continuous excitation
Start delay	7s
Fault time	3s
ETR time without terminal 50	30s after pre-glowing
Cable start detection	via oil and D+
PMT-3 expansion	Yes
Features	<ul style="list-style-type: none"> • Operating LED (flashing) as pre-glowing display • State info of PMT-3 comes via input Pin 8 (Ext.Stop) • Cable start • Continuous excitement at input D+ <p>Functions with PMT-3 and software S02135-2:</p> <ul style="list-style-type: none"> • Fixed 5s pre-glowing in PMT-3, hidden additional 2s. Without terminal 50 with 20s after-glowing. • PMT-3, X10 as external stop First time external stop alarm acknowledgement Second time external stop switches the engine off • Starter engagement protection

Tab. 10: Software data S02366

4.9 Item no.: ehb 5130B, ehb 5132-B, ehb 5456

Software no.	S02367
Item no.:	ehb 5130-B ehb 5132-B ehb 5456
Pin 6, Output 1 (3A)	ETR-HC 30s
Pin 7, Output 2 (3A)	Vg6s Ng0s with 50
X105, Output 3 (20A)	ETR-HC 30s
Pin 1, Oil pressure	stopping, NC
Pin 2, Alternator D+	stopping, NC
Pin 3, Temperature	stopping, NO
Pin 4, Diverse	stopping, NO
Pin 8, Ext. Stop	stopping, NO
Excitation	with terminal 50 continuous excitation
Start delay	7s
Fault time	3s
ETR time without terminal 50	30s after pre-glowing
Cable start detection	via oil and D+
PMT-3 expansion	No
Features	<ul style="list-style-type: none"> • Operating LED (flashing) as pre-glowing display • Output pre-glowing active during start • Cable start • Continuous excitement at input D+

Tab. 11: Software data S02367

4.10 Item no.: ehb 5333-C, ehb 5471, ehb 5477

Software no.	S02368
Item no.:	ehb 5333-C ehb 5471 ehb 5477
Pin 6, Output 1 (3A)	ETR-HC 12s
Pin 7, Output 2 (3A)	Vg5s Ng0s without 50
X105, Output 3 (20A)	ETR-HC 12s
Pin 1, Oil pressure	stopping, NC
Pin 2, Alternator D+	stopping, NC
Pin 3, Temperature	stopping, NO
Pin 4, Diverse	stopping, NO
Pin 8, Ext. Stop	stopping, NO
Excitation	with terminal 50 continuous excitation
Start delay	7s
Fault time	3s
ETR time without terminal 50	12s after pre-glowing
Cable start detection	via oil and D+
PMT-3 expansion	No
Features	<ul style="list-style-type: none"> • Operating LED (flashing) as pre-glowing display • Cable start • Continuous excitement at input D+

Tab. 12: Software data S02368

4.11 Item no.: ehb 5457, ehb 5472, ehb 5478

Software no.	S02369
Item no.:	ehb 5457 ehb 5472 ehb 5478
Pin 6, Output 1 (3A)	ETR-HC 12s
Pin 7, Output 2 (3A)	Vg8(+1)s Ng0s without 50
X105, Output 3 (20A)	ALARM SIGNAL
Pin 1, Oil pressure	stopping, NC
Pin 2, Alternator D+	stopping, NC
Pin 3, Temperature	stopping, NO
Pin 4, Diverse	warning, NC
Pin 8, Ext. Stop	stopping, NO
Excitation	with terminal 50 continuous excitation
Start delay	7s
Fault time	3s
ETR time without terminal 50	No ETR output
Cable start detection	via oil and D+
PMT-3 expansion	No
Features	<ul style="list-style-type: none"> • Operating LED (flashing) as pre-glowing display • For faults at Pin 1, Pin 2 and Pin 3, the LED display is locked and the operating magnet switched off. • Cable start • Continuous excitement at input D+

Tab. 13: Software data S02369

4.12 Item no.: ehb 5466, ehb 5473, ehb 5479

Software no.	S02370
Item no.:	ehb 5466 ehb 5473 ehb 5479
Pin 6, Output 1 (3A)	ETR-HC 12s
Pin 7, Output 2 (3A)	ALARM SIGNAL
X105, Output 3 (20A)	ETR-HC 12s
Pin 1, Oil pressure	stopping, NC
Pin 2, Alternator D+	stopping, NO
Pin 3, Temperature	stopping, NO
Pin 4, Diverse	stopping, NO
Pin 8, Ext. Stop	stopping, NO
Excitation	without
Start delay	7s
Fault time	3s
ETR time without terminal 50	--
Cable start detection	via oil and D+
PMT-3 expansion	No
Features	<ul style="list-style-type: none"> • Input alternator Pin2 responds invertedly. This means mass is not a fault. The excitation in D+ is switched off. Switch open or +Ub or wire break is fault. • Cable start

Tab. 14: Software data S02370

4.13 Item no.: ehb 4394-H, ehb 4318-G

Software no.	S02373
Item no.:	ehb 4394-H ehb 4318-G
Pin 6, Output 1 (3A)	ETS-HC 20s
Pin 7, Output 2 (3A)	ALARM SIGNAL
X105, Output 3 (20A)	ETS-HC 20s
Pin 1, Oil pressure	stopping, NC
Pin 2, Alternator D+	stopping, NC
Pin 3, Temperature	stopping, NO
Pin 4, Diverse	stopping, NO
Pin 8, Ext. Stop	stopping, NO
Excitation	with terminal 50 continuous excitation
Start delay	7s
Fault time	3s
ETS time without terminal 50	ETS 20s
Cable start detection	via oil and D+
PMT-3 expansion	No
Features	<ul style="list-style-type: none"> • Operation LED lights up continually, except for fault • Cable start • Continuous excitement at input D+

Tab. 15: Software data S02373

4.14 Item no.: ehb 5536

Software no.	S02446
Item no.:	ehb 5536
Pin 6, Output 1 (3A)	ETR-HC 12s
Pin 7, Output 2 (3A)	Vg0s Ng3s with 50
X105, Output 3 (20A)	ETR-HC 12s
Pin 1, Oil pressure	stopping, NC
Pin 2, Alternator D+	stopping, NC
Pin 3, Temperature	stopping, NO
Pin 4, Diverse	stopping, NO
Pin 8, Ext. Stop	stopping, NO
Excitation	with terminal 50 continuous excitation
Start delay	7s
Fault time	3s
ETR time without terminal 50	ETR12s
Cable start detection	via oil and D+
PMT-3 expansion	No
Features	<ul style="list-style-type: none"> • Operating LED (flashing) as pre-glowing display • Continuous excitement at input D+ • Choke function via after glow with T.50

Tab. 16: Software data S02446

5 Functional description

5.1 Operating and display elements



Fig. 2: Operating and display elements

No.	Description
1	Operation LED (green)
2	LED charge control "D+" (red)
3	LED engine oil pressure (red)
4	LED engine temperature (red)
5	LED diverse/pre-glowing (red)
6	Ignition switch
7	Operating hours counter

5.2 Self-test

After turning the ignition key to position 1, the controller performs a self-test. All LEDs light up 3 times.

5.3 Ignition switch

The ignition switch is provided with a mechanical restart lock.

Function of the ignition switch

Position	Meaning
0	Device is switched off
1	Ignition switched on. Pre-glowing function starts Operating magnet is switched on
2	Start with mechanical restart lock

Tab. 17: Ignition switch function

5.4 Starter protection function

The controller has a mechanical restart lock in the ignition switch. After inserting the ignition key, it can be turned in all positions. After turning to position 2, the ignition key reverts to position 1. Position 2 is then mechanically locked and can only be reached again when the ignition key has been turned to position 0.

5.5 Start optimisation

1. Switch on ignition by turning the ignition key to position 1. The self-test is performed.
2. When the pre-glowing function is active, the green Operation LED flashes or the Diverse LED lights up depending on the software version. During this time, the output for the lifting magnet / solenoid valve is also active. If the engine is not started during this time, then the output is deactivated again to reduce the power consumption.
3. After the engine starts, the Operation LED continually lights up and the states of all inputs are displayed with the other LEDs. If a fault is detected, the Operation LED goes out. The engine can be started at any time by turning the ignition key to position 2.

5.6 Pre-glowing function

- The pre-glowing function is displayed by the flashing green LED or an illuminated Diverse LED depending on the software version.
- Normally the MC 704 V3 is programmed with a software-specific fixed pre-glowing time that is activated independent of the external temperature when switched on.
- If the green LED lights up continually or the Diverse LED goes out, the pre-glowing procedure is completed and start-up can proceed.
- If start-up proceeds during the pre-glowing function, the pre-glowing output is engaged, interrupted or completely cancelled at the start for 300 ms depending on the software version. Afterwards the pre-glowing function is continued with the start procedure until it ends or the after-glowing function follows.
- The after-glowing time is also programmed with a fixed time specific to the software. The after-glowing function starts after the falling edge at input terminal 50.

Optional: Temperature-dependent pre-glowing for item number ehb 5467 and ehb 5084-E, optional with additional board PMT-3

- The pre-glowing time is 20 seconds between 0°C and -30°C.
- The pre-glowing time is 90 seconds below -30°C.
- The after-glowing time is half of the pre-glowing time.

5.7 Operating hours counter

Operating hours are counted when a running engine has been detected above the oil pressure and input generator terminal “D+”.

5.8 Engine monitoring with fault shutdown

If fault switches are monitored, then they are switched to ground at the inputs of the device. The monitoring of the switches starts 7 seconds after the engine starts. The state of the switches is displayed by the LEDs.

If a switch changes its state during operation for 3 seconds, the engine is automatically stopped or a warning is given depending on the software version. Faults that are present for less than 3 seconds are summed and saved. If the saved value exceeds 3 seconds, then the engine is also stopped. If no more fault occurs for 10 seconds, then the memory is deleted.

The first fault to occur is saved and the other inputs are locked so that it can always be properly determined which fault caused shutdown even when the input has adopted its normal state in the meantime.

5.9 Cable start detection

The manual start of combustion engines with cable start equipment or hand cranks is detected by the cable start detection function. When a cable start has been detected, the MC704 automatically starts monitoring inputs PIN 1-4 for oil pressure, temperature, charge control and diverse even when terminal 50 for the starter was not switched.

Monitoring of the engine functions starts when the inputs for oil pressure and generator D+ are not connected to ground.

Caution: For devices with inverted input for generator D+, a cable start is detected when an open contact is present at input Pin 1 oil pressure and input Pin 2 generator D+ is connected to ground.

6 Commissioning

6.1 Installation and connection information

Installation site

The selection of the installation site at the machine has a direct effect on the service life of the device.

- Select the installation site so that the device is protected as much as possible against external influences, e.g. extreme temperature, moisture and vibration.
- Observe the specifications in the Technical data chapter here.

Accessories (option)

If required, the following accessories for installation or connection can be ordered from ehb electronics gmbh.

- Shock mounts for fastening to a flange.
- Customer-specific cable harnesses

Installation

1. Either fasten the device with the U-bracket in a section of the control panel or with the threaded bushes and suitable shock mounts (accessory) to a flange.

Connection

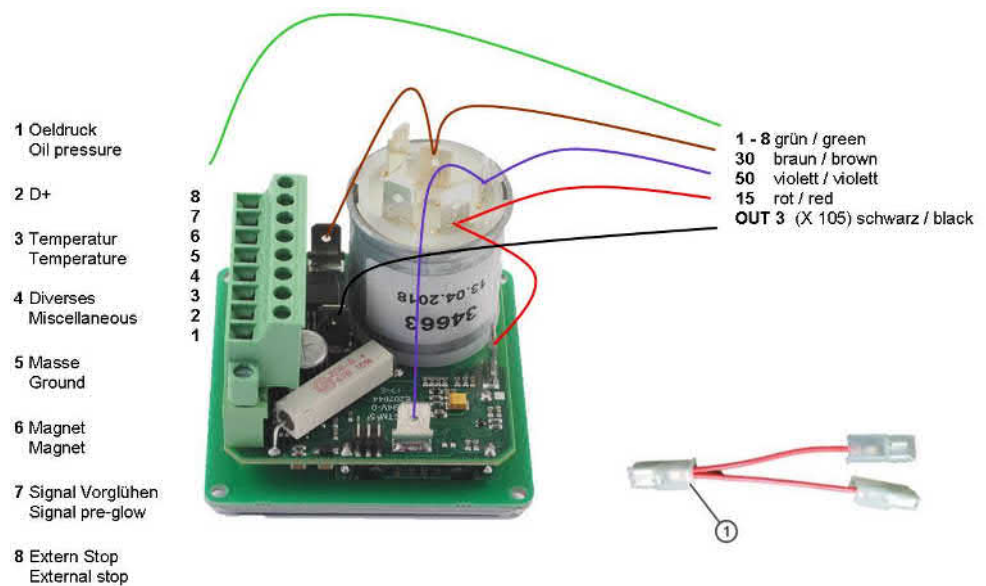

Fig. 3: Connections (example)

1. Unscrew 4 screws at the front plate and remove front plate.
2. To connect either use the supplied cable harness (accessory) or a suitable self-provided cable harness.
3. Guide all connection cables through the cable gland at the rear of the housing.
4. Secure the connection cables from the inside with a cable tie to protect them from being unintentionally pulled out.
5. Establish connection according to Connection Plan chapter.
6. Connect each of the terminals 15, 30 and 50 via a Y-Adapter with spade connectors, see example (1).
7. Tighten screws at 8-pole Phoenix connector after inserting.

NOTE

All switching inductors must be equipped with a free-wheeling diode.

Unused inputs can remain free.

The IS connection for programming the device may not be guided outwards as otherwise the processor could get damaged.

Upgrading the temperature switches

Observe the following information when upgrading the temperature switches:

- Mount temperature switch for water-cooled engines in the water circuit (warm side).
- Mount temperature switch for air-cooled engines in the cylinder head.
- For combined sensors/switches, connect the large connection (6.3 mm) with the temperature instrument and the small connection (4.8 mm) with the MC 704 V3.

Upgrading a lifting magnet for engine shutdown

Observe the following information when upgrading a lifting magnet for engine shutdown:

- It must be possible for the heat at the lifting magnet to escape upwards unhindered.
- Mount lifting magnet to the side of the stop lever of the injection pump.
- Connect lifting magnet and stop lever of the injection pump with a threaded rod. Make sure that the pulling direction runs parallel and swinging does not occur.

Upgrading a solenoid valve for engine shutdown

Observe the following information when upgrading a solenoid valve for engine shutdown:

- Mount solenoid valve directly in front of the injection pump.
- Make sure that the engine is not supplied with fuel via the return line.

6.2 Connection diagram diesel engines

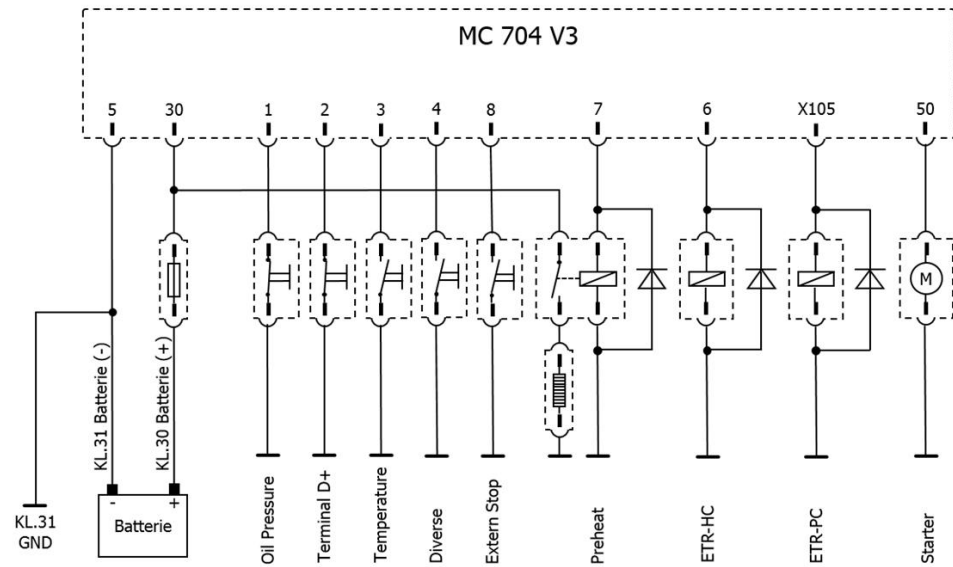

Fig. 4: Wiring plan example for diesel engines - the connections vary depending on the software version

No.	Description	No.	Description
1	Low power contacts 8-pole Phoenix green	1	Oil pressure
		2	Terminal "D+" (excitation)
		3	Temperature
		4	Diverse
		5	Terminal "31" input battery / ground
		6	Output 1 max. 3A (e.g. op. magnet-HW)
		7	Output 2 max 3A (z. B. signal/pre-glowing)
		8	External stop
2	ISP programming plug	1-6	ISP standard assignment
3	High power contacts 6.3mm vehicle	50	Terminal "50" output for starter
4		15	Terminal "15" output switched voltage supply
5		OUT3	Terminal "X 105" output max. 20A (e.g. magnet AW)
6		30	Terminal "30" input battery +

Tab. 18: Inputs and outputs

6.3 Connection diagram gasoline engines

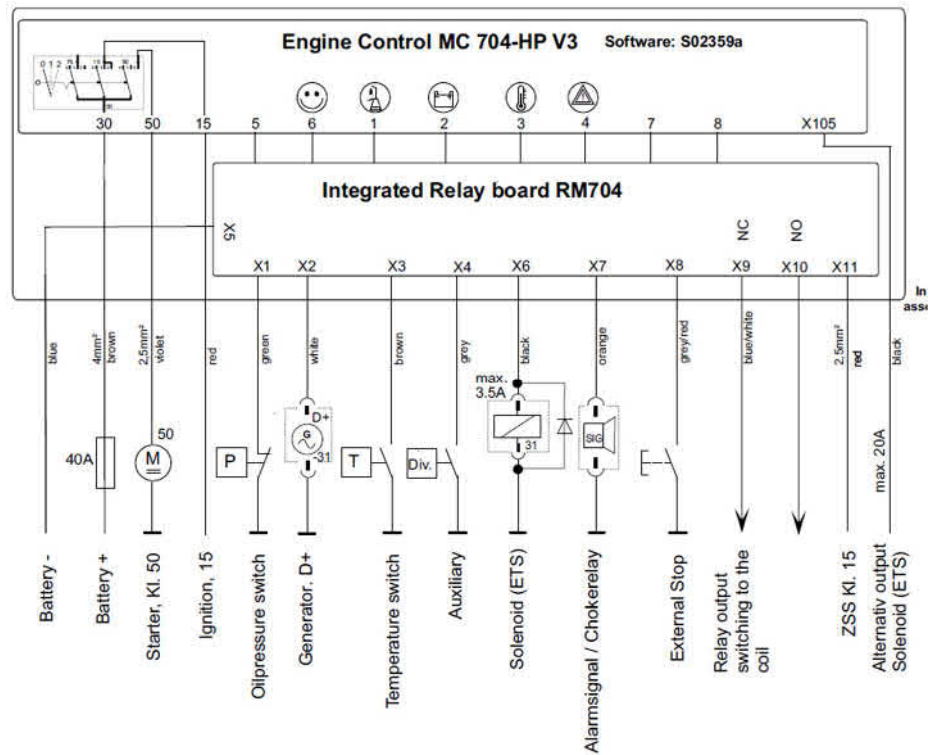

Fig. 5: Wiring plan example for gasoline engines - the connections vary depending on the software version

No.	Description	No.	Description
1	Low power contacts 8-pole Phoenix green	1	Oil pressure
		2	Terminal "D+" (excitation)
		3	Temperature
		4	Diverse
		5	Terminal "31" input battery / ground
		6	Output 1 max. 3A (e.g. op. magnet-HW)
		7	Output 2 max 3A (z. B. signal/choke)
		8	External stop
2	ISP programming plug	1-6	ISP standard assignment
3	High power contacts 6.3mm vehicle	50	Terminal "50" output for starter
4		15	Terminal "15" output switched voltage supply
5		OUT3	Terminal "X 105" output max. 20A (e.g. magnet AW)
6		30	Terminal "30" input battery +

Tab. 19: Inputs and outputs

7 Operation

7.1 Status displays



Fig. 6: Status displays LED

No.	Description
1	Operation LED (green) – flashes for pre-glowing (software -specific)
2	LED charge control “D+” (red)
3	LED engine oil pressure (red) – fault display
4	LED engine temperature (red) – fault display
5	LED diverse (e.g. air filter) (red) – fault display

7.2 Start engine

1. Switch on ignition by turning the ignition key to position 1.
2. Wait 3 seconds until the self-start has been performed.
3. If possible wait for the pre-glowing procedure.
4. Start engine by turning the ignition key to position 2.

7.3 Stop engine

1. Stop engine by turning the ignition key to position 0.

8 Troubleshooting

8.1 Fault detection

- Before starting, i.e. ignition key in position 1, the LEDs display the state of the inputs.
- Cable break detection for engine at standstill for the inputs "Oil pressure" and "D+":
Monitoring of the inputs only starts 7 seconds after the start to allow the engine to build up oil pressure and charge voltage.
- A fault at a stopping input (e.g. engine oil pressure) during operation leads to the shutdown of the output ETR-operating magnet after 3 seconds and thus the shutdown of the engine.
- Only the input that led to the shutdown of the engine is displayed. All other displays are suppressed. In this way, it can be properly determined which fault caused the shutdown of the engine.

8.2 External stop / fault acknowledgement

- If a switch is connected to the input External Stop, the engine is stopped for an active switch.
- If a button is connected to the input External Stop, a fault input that does not switch off while the engine is running can be reset (acknowledged) by pressing this button of the signal output once in the event of a fault depending on the software version.
However the acknowledged fault is still displayed by the relevant LED.
- If the External Stop button is pressed a second time for the corresponding software version, the ETR-operating magnet is switched off and the engine stops.

8.3 Troubleshooting

Error

The device does not switch on.

The engine starts when switched on but not when started.

The controller does not respond to the input signals.

The engine speed fluctuates widely.

A measurement at the output shows a transistor turned on although it should have a high resistance.

Rectification

Supply voltage connected with reverse polarity. The reverse polarity protection does prevent damage to the electronics but does not replace the correct polarity of the connection lines.

The lines for terminal 15 and terminal 50 were reversed during connection.

Inputs must be switched to ground. The controller cannot detect positive signals.

The output is overloaded and the transistor closes. When it has cooled down, it connects through.

As a result, the hold-in winding of the operating magnet draws in and falls again.

A load must be connected to the output. Otherwise the Open-Load-Detection behaves like a low resistance transistor.

9 Decommissioning

NOTE

- Decommission the device according to the applicable local regulations and laws.
-

9.1 Disposal

Note concerning environmental protection

Risk of environmental damage

Improper disposal may have an environmental impact.

- Observe the local regulations and legal provisions for disposal.
-

10 Maintenance

10.1 Maintenance of the MC 704 V3

The MC 704 V3 is maintenance-free.

Cleaning



ATTENTION

Never use a high-pressure cleaner to clean the device.
High pressure cleaning causes damage to the device.

10.2 Repair

Should the device require repair work, please return it to:

ehb electronics gmbh
Hans-Böckler-Str. 20
30851 Langenhagen
GERMANY

Please make sure that you include a written fault description. This will facilitate the work of the ehb electronics gmbh service department and ensure faster return of your MC 704 V3 .

Alternatively you can use our online service for the returning of devices:
www.ehbservice.de

NOTE

ehb electronics GmbH assumes liability only for the proper execution of services and the correct characteristics of the materials used.

Any further claims such as for loss of profit and for direct and indirect consequential damages such as loss of data are excluded.

ATTENTION

Damages arising from improper packaging of the device for shipping and/or unauthorised intervention will invalidate the guarantee.

11 Index

A			
About these instructions	5		
C			
Commissioning	28		
Connection diagram	31		
D			
Decommissioning	35		
Disposal	35		
E			
Engine monitoring.....	27		
External stop.....	33		
F			
Fault acknowledgement.....	33		
Fault detection	33		
Fault shutdown	27		
Functional description.....	25		
G			
General information on safety	7		
I			
Ignition switch	26		
Installation and connection information	28		
Intended use	8		
Item no.			
ehb 4394-H, ehb 4318-G.....	24		
ehb 4913-3B, ehb 5469, ehb 5474	14		
ehb 5084-E	17		
ehb 5130B, ehb 5132-B, ehb 5456	20		
ehb 5182-D.....	19		
ehb 5321-A, ehb 5470, ehb 547515			
ehb 5333-C, ehb 5471, ehb 5477	21		
ehb 5457, ehb 5472, ehb 5478 ..	22		
ehb 5466, ehb 5473, ehb 54798	23		
ehb 5467.....	16		
ehb 5468	18		
Item no.			
ehb 4315-I, ehb 4393-1F, ehb 4393-K.....	12		
ehb 4752-3A, ehb 4752-I, ehb 5185-B.....	13		
M			
Maintenance	36		
N			
Notes - Presentation.....	6		
O			
Operating and display elements....	25		
Operating hours counter.....	27		
Operation.....	32		
P			
Pre-glowing function.....	26		
Q			
Qualification of personnel.....	8		
R			
Repair	36		
S			
Safety	7		
Self-test	25		
Software versions.....	12		
Start engine	32		
Start optimisation.....	26		
Starter protection function	26		
Status displays	32		
Stop engine	32		
Symbols and abbreviations	5		
T			
Target group.....	5		
Technical data	9		
Troubleshooting.....	33, 34		
U			
Use and safekeeping.....	5		

12 Documentation information and history

Project:	MC 704 V3
Type of document:	Technical document
Version:	1.0
Prepared on:	15.01.2018
Prepared by:	ehb electronics gmbh, Hanover

Revisions:

Version:	Preparation/Revisions:	Prep./Rev. date:	Preparer/R eviser(s):
1.0	First edition of the operating manual, provisional approval	15.01.2018 24.01.2018	Hk/Hag BR/Hag
1.1	Div. adaptations	24.04.2018	Hk/Hag
1.2	Connection, page 28	14.08.2018	Hk/Hag
1.2	Connection, page 28	04.12.2018	Hk/Jäk/Hag
1.3	Gasoline engines added copyedit	26.01.2021 26.01.2021	Hk Hag



Tel. +49-511-12 32 07-0
 Fax +49-511-12 32 07-77
 E-mail: info@ehb-electronics.de

Hans-Böckler-Str. 20
 30851 Langenhagen
 GERMANY

www.ehb-electronics.de
 www.ehbshop.de
 www.ehb-service.de