

Technical Information

Joysticks

JS1000, JS6000 Grips



Revision history

Table of revisions

Date	Changed	Rev
October 2020	Changed document number from 'BC00000072' and '520L0872' to 'BC152886483977'	0903
February 2018	New boot part number	0801
June 2016	Corrected part numbers for Rocker switch and Banana switch covers; updated to Engineering Tomorrow design	0702
February 2016	Converted to Danfoss layout	0701
June 2013	Grip Button Color Options table	HA
January 2010	A Grip Front Plate Diagram illustration	GA
December 2009	Pro grip recommendation, IP rating	FA
September 2008	obsolete joystick removed, replaced with ball grip	EA
04 Jan, 2008	Content update	DA
December 2005	Operating and storage temperature updated	C

Contents

General Information

Introduction.....	4
JS1000, JS6000 grip selection guide.....	4
Grip options and joystick base compatibility.....	4
Product configuration model code.....	5

JS1000 grips

JS1000 base model code.....	6
JS1000 grip model code.....	7
PRO grip.....	10
Overview.....	10
Model code nomenclature.....	10
Specifications.....	10
Connector pin assignments.....	11
Front plate model code designations.....	12
Dimensions.....	13
Grip with rocker switch and grip with banana switch.....	14
Overview.....	14
Model code nomenclature.....	14
Specifications.....	14
Connector pin assignments.....	15
Grip with rocker switch dimensions.....	15
Grip with banana switch dimensions.....	16
Ball grip.....	17
Overview.....	17
Model code nomenclature.....	17
Specifications.....	17
Connector pin assignments.....	17
Dimensions.....	18

JS6000 grips

JS6000 base model code.....	19
JS6000 grips model code.....	20
JS6000 connector pin assignments.....	22
A grip.....	23
Overview.....	23
Model code nomenclature.....	23
Front plate model code designations.....	25
Rocker switch profiles.....	26
Rocker switch specifications.....	26
Rocker switch wiring details.....	27
Pushbutton specifications.....	28
Pushbutton wiring details.....	29
A grip connector pin assignments.....	30
Dimensions.....	33
MG grip.....	34
Overview.....	34
Model code nomenclature.....	35
Specifications.....	36
MG grip connector pin assignments.....	36
Switch wiring details.....	37
Dimensions.....	39
HKN grip.....	40
Overview.....	40
Model code.....	40
Environmental specifications.....	40
Dimensions.....	40

Service parts

JS1000 service part availability.....	41
---------------------------------------	----

General Information

Introduction

Danfoss joysticks offer mobile machine product engineers a wide array of grip designs. Each of the grip designs outlined in this document meets the demanding conditions typically found in mobile equipment environments.

The many available grip features provide OEM engineers with options offering a high degree of protection from chemicals, high-pressure wash, shock, vibration and EMC exposure. Danfoss grips are appropriate for both in-cabin and out of cabin applications and feature ergonomic forms that minimize machine operator fatigue.

This publication provides technical information required to specify the grip portion of JS1000 and JS6000 joysticks. Danfoss JS1000 Joystick Base Technical Information, **BC152886484104** and JS6000 Joystick Base Technical Information, **BC152886483634** provide technical information required to specify joystick bases.

JS1000, JS6000 grip selection guide

Grip options and joystick base compatibility

Use the following table to determine which joystick base mates with specific Danfoss joystick grips.

JS1000, JS6000 grip options and joystick base compatibility

Grip designation	Compatible with		Grip functionality (maximum number)			Operator presence
			Momentary switches	Proportional inputs		
	JS1000 base	JS6000 base		Rocker	Banana	
PRO	X		X (6)			X (2)
Grip with Rocker Switch	X			X (1)		
Grip with Banana Switch	X				X (1)	
Ball	X					
A		X	X (8)	X (2)		X (1)
MG		X	X (2)			X (1)
HKN		X				

JS1000, JS6000 grips



General Information**Product configuration model code**

A product configuration model code (model code) is used to specify particular features when ordering JS1000 or JS6000 joysticks. The model code begins with the product family name and the remaining fields are filled in to configure the product with the desired features.

JS1000 and JS6000 model codes contain information relating to both base features and grip features.

JS1000 grips

JS1000 base model code

JS1000 grip product configuration model code example—base part A, B, C, D and E1

A						B		C	D			E			F			G		H				J
1	2	3	1																					
J	S	1	0	0	0	X	Y	A	J	3	3	1	T											

A—Product family

Code	Description
JS1000	JS1000 joystick base with DEUTSCH connector, spring return to center

B—Single or dual axis

Code	Description
XY	Dual axis function, forward and reverse with left and right, with guided axis (force is increased in the corners)
NY	Single axis function, forward and reverse
NG	Dual axis function, without guided axis feel (free moving in all directions)

C—Center return spring

Code	Description
A	Standard spring
B	Heavy spring

D1—Electrical interface options

Code	Description
J	CAN with J1939 message protocol
S	Analog voltage output

D2—Joystick CAN source address

Code	Description
NN	None—use with analog output (when D1=S)
33	Source address = 33 (hex)
34	Source address = 34 (hex)
35	Source address = 35 (hex)
36	Source address = 36 (hex)

D3—Joystick output type

Code	Description
N	None—use with analog output (when D1=S)
1	CAN full scale output = 1000 counts

E1—Grip mounting options

Code	Description
B	Bottom mount (from below the panel, no boot retainer included, boot is captured between panel and housing) with vent plug*
C	Bottom mount (from below the panel, no boot retainer included, boot is captured between panel and housing) without vent plug*

JS1000 grips

E1—Grip mounting options (continued)

Code	Description
T	Top mount (from above the panel, includes boot retainer for attaching boot to joystick housing) with vent plug*
U	Top mount (from above the panel, includes boot retainer for attaching boot to joystick housing) without vent plug*

* Vent plug is a Gore-Tex® moisture barrier. If the plug is not present, Ingress Protection below the base is unrated.

[PRO grip option top mount only.](#)

JS1000 grip model code

JS1000 grip product configuration model code example—joystick part E2 and F

A					B		C	D				E				F				G		H					J				
												1	2			1	2	3	4												
J	S	1	0	0	0	X	Y	A	J	3	3	1	T	P	R	O	R	3	R	R											

E2—Grip mounting and handle options

Code	Description
PRO	PRO grip, CAN output. Complete section F, G, H, J
PR1	PRO grip, with no switch or proportional functions, CAN output.
K01	Ball grip Do not complete F, G, H, J
LSW	Grip with analog rocker switch, 1.15 to 3.75 V DC range. Do not complete F, G, H, J
LSB	Grip with banana switch, 1.15 to 3.75 V DC range. Do not complete F, G, H, J

[PRO grip available with CAN option only. Grips with switches available with analog option only.](#)

F1—PRO grip function layout

Code	Description
R...	Right handed grip
L...	Left handed grip

F2—PRO grip function layout

Code	Number of switches on the front plate
.0..	No switches
.1..	1 switch
.2...	2 switches
.3..	3 switches
.4..	4 switches
.5..	5 switches

F3—PRO grip function layout

Code	Type of proportional function
..R.	Roller or wheel, not sealed
..N.	None

JS1000 grips

F4—PRO grip function layout

Code	Position of proportional function
...N	No proportional function required
...R	Vertical proportional function on the Right-hand side
...L	Vertical proportional function on the Left-hand side
...B	Horizontal proportional function on the Bottom
...D	Vertical proportional functions on both the left and the right-hand sides
...S	Horizontal proportional functions as dual set on the top and the bottom
...T	Horizontal proportional function on top

JS1000 grip product configuration model code example—joystick part E2 and F

A						B		C	D				E				F				G		H				J		
																					1	2							
J	S	1	0	0	0	X	Y	A	J	3	3	1	T	P	R	O	R	3	R	L	R	Y	Y	N	R	N	G	N	

F—Grip function layout examples

R0NN	Right handed, 0 switches, No roller, No position	R2RL	Right handed, 2 switches, Roller, Left positioned
R1NN	Right handed, 1 switches, No roller, No position	R3RL	Right handed, 3 switches, Roller, Left positioned
R2NN	Right handed, 2 switches, No roller, No position	R0RB	Right handed, 0 switches, Roller, Bottom positioned
R3NN	Right handed, 3 switches, No roller, No position	R1RB	Right handed, 1 switches, Roller, Bottom positioned
R4NN	Right handed, 4 switches, No roller, No position	R2RB	Right handed, 2 switches, Roller, Bottom positioned
R5NN	Right handed, 5 switches, No roller, No position	R3RT	Right handed, 3 switches, Roller, Top positioned
R0RR	Right handed, 0 switches, Roller, Right positioned	R0RD	Right handed, 0 switches, 2 Roller, Dual positioned
R1RR	Right handed, 1 switches, Roller, Right positioned	R1RD	Right handed, 1 switches, 2 Roller, Dual positioned
R2RR	Right handed, 2 switches, Roller, Right positioned	R0RS	Right handed, 0 switches, 2 Roller, Stacked positioned
R3RR	Right handed, 3 switches, Roller, Right positioned	R1RS	Right handed, 1 switches, 2 Roller, Stacked positioned
R0RL	Right Handed, 0 switches, Roller, Left positioned	R2NR	Right handed, 2 switches, No roller, Right positioned
R1RL	Right Handed, 1 switches, Roller, Left positioned	R2NL	Right handed, 2 switches, No roller, Left positioned

G1—PRO grip side switch orientation

Code	Description
R.	Right handed PRO Grip
L.	Left handed PRO Grip

G2—PRO grip side switch color

Code	Description
.R	Red side switch
.Y	Yellow side switch
.B	Black side switch
.G	Grey side switch
.N	No side switch

JS1000 grips

H—PRO grip front plate switch color selection examples

Code	Description
NNNNN	No switches (diagram 0NN*)
RYBGR	Position 1 switch Red, position 2 switch Yellow, position 3 switch Black, position 4 switch Grey, position 5 switch Red (diagram 5NN*)
YYYYY	5 Yellow switches (diagram 5NN*)
RNNRB	Position 1 switch Red, No position 2 switch, No position 3 switch, position 4 switch Red, position 5 switch Black (diagram 3NN*)
YRNNN	Position 1 switch Yellow, Position 2 switch Red, No position 3 switch, No position 4 switch, No position 5 switch (diagram 2RL*)

* See [Front plate model code designations](#) on page 12. Number refers to button location on grip front panel. Select one color code for each switch specified.

J—Operator Presence switch option not available

Code	Description
N	No: operator presence switch option not selected

JS1000 grips

PRO grip

PRO grip



Overview

The PRO grip is a patented ergonomic joystick grip that is designed to minimize operator fatigue in operations requiring repetitive, precision movement over extended periods of time. The grip is available in right and left hand versions. The profile of the PRO grip ensures that the operators fingers are close to input functions thus maximizing functional control. The hand rest at the base of the grip and *soft feel elastomeric palm insert* contributes to a comfortable feel and provides additional protection for the joystick boot.

A unique feature of the grip is the intelligent embedded electronics that allows joystick input information to be multiplexed into a two-wire serial signal communicating with base electronics. The intelligent electronics facilitate the compact design of the grip by eliminating the need to pass large numbers of discrete wires through the joystick shaft.

The PRO grip is available with a maximum of six switch inputs or two proportional inputs, or a mix of switch and proportional inputs.

The PRO grip is not recommended in an open cab environment.

Model code nomenclature

Grip and grip options are specified using the Danfoss joystick model code. For grips designed to mate with the JS1000 joystick base, use code positions E2, F, G and J to specify grip properties. Reference [JS1000 base model code](#) on page 6.

The PRO grip uses all portions of the model code. Other JS1000 grips use only the E2 portion of the model code.

Specifications

PRO grip switches and proportional rollers are internally wired to a microcontroller located in grip. Grip information is included in joystick base CAN messages.

Electrical

Description	Specification
Switch action	Momentary
Switch type	Single pole, NO
Switch mechanical life	1 million cycles

JS1000 grips

Environmental

Description	Specification
Operating temperature	-30°C to 75°C [-22°F to 167°F]
Storage temperature	-40°C to 85°C [-40°F to 185°F]
Environmental sealing (without proportional roller)	IP 43

Proportional Roller Specifications

Description	Specification
Roller action	Spring return to center
Roller electrical output	±1000 counts from null
Roller mechanical life	5 million cycles
Environmental sealing	IP 40

[Proportional rollers are not to be used in no cabin or open cabin joystick applications.](#)

Connector pin assignments

PRO grips mounted on JS1000 joystick bases that have user inputs—switches, proportional inputs or a mix of both—must use the CAN electrical output option to transmit grip switch and proportional function information. Refer to the *JS1000 Joystick Base Technical Information, BC152886484104* for grip CAN message details and connector pin assignments.

JS1000 grips

Front plate model code designations

PRO grip front plate diagram

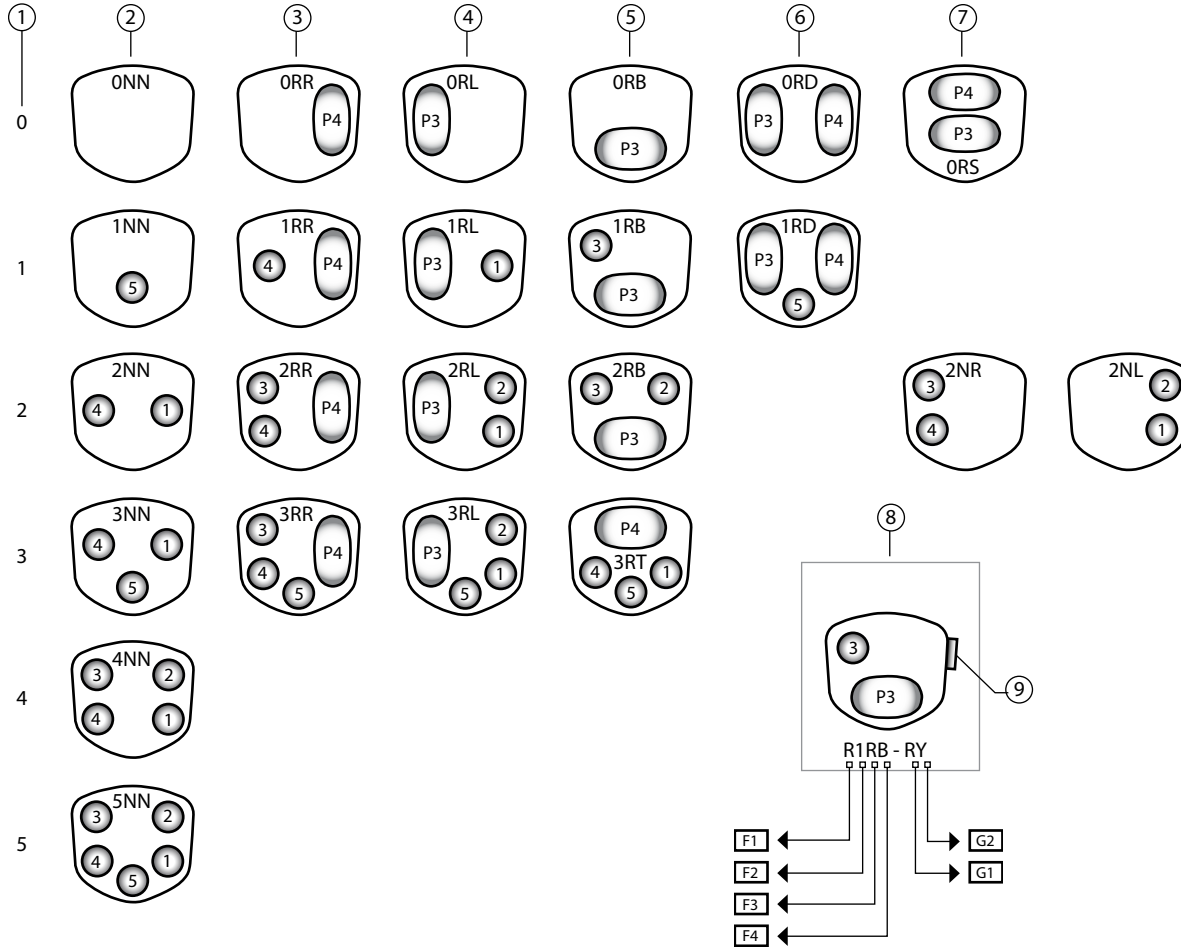

- 1. Number of switches
- 2. 0 Proportional function in grip (prop)
- 3. Right prop
- 4. Left prop
- 5. Bottom/top prop
- 6. Dual prop
- 7. Stacked prop
- 8. Front plate configuration example
- 9. Position 6

Pushbutton colors

R	Red
Y	Yellow
B	Black
G	Grey
N	None

kw11392484982079

JS1000 grips

Dimensions

Pro grip dimensions in millimeters [inches].

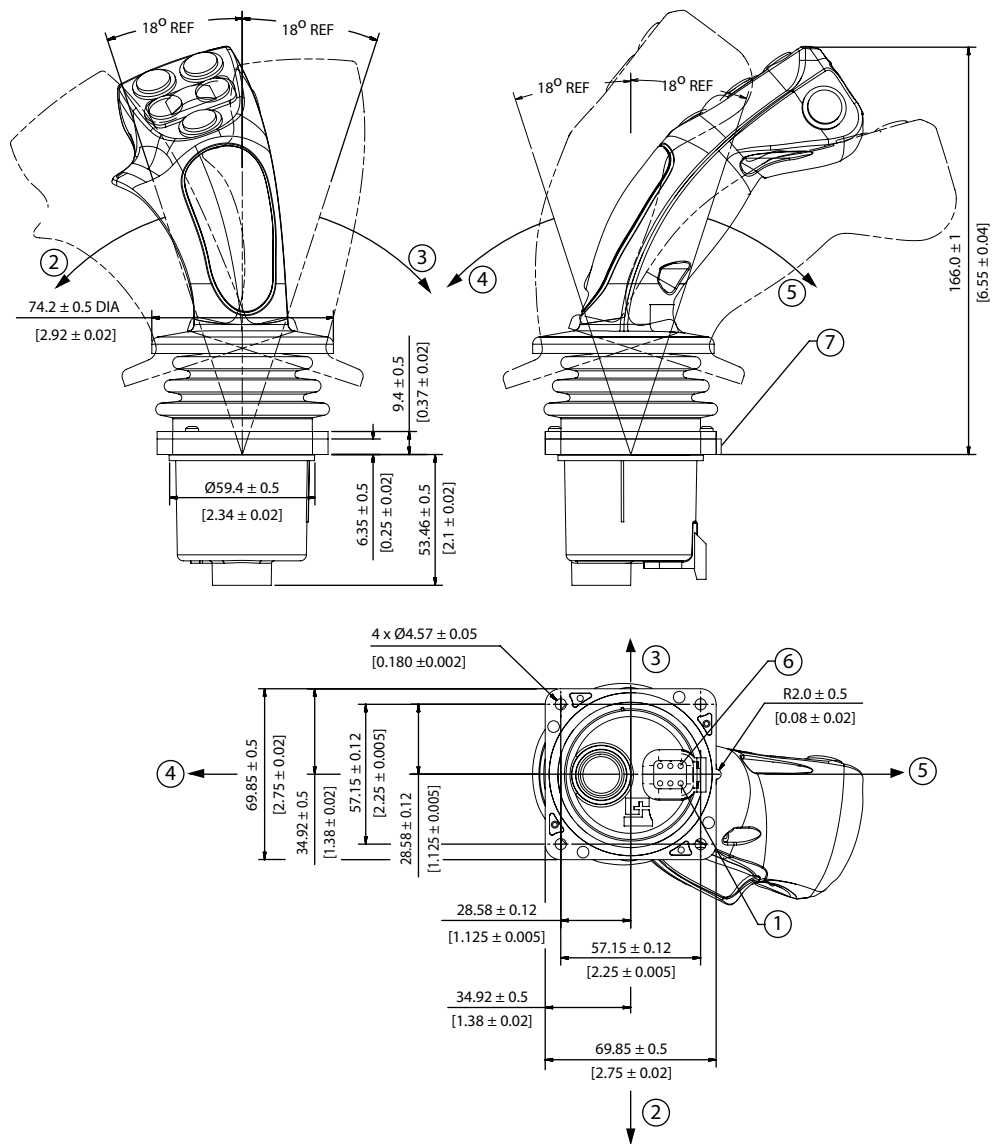

kwa1392484997286

- 1. Pin 1
- 2. Decreasing X
- 3. Increasing X
- 4. Decreasing Y
- 5. Increasing Y
- 6. Pin 6
- 7. Orientation feature

JS1000 grips

Grip with rocker switch and grip with banana switch

Grip with rocker switch and grip with banana switch



Overview

JS1000 grips with switches are intended to provide a simple, flexible and comfortable operator control that includes a proportional input device at the top of the grip. Two shapes are available for the proportional input device: *V rocker* or *banana rocker*. Both grips use Hall sensing technology to detect rocker switch position.

The proportional input generates a nominal 0 to 5 Vdc signal that is used as a change of state (switch) input.

Model code nomenclature

Grip and grip options are specified using the Danfoss joystick model code. For grips designed to mate with the JS1000 joystick base, use code positions E2, F, G and J to specify grip properties. Reference [JS1000 base model code](#) on page 6

The grip with rocker switch and grip with banana switch are designated using only the E2 portion of the code.

Specifications

Top switch electrical

Description	Specification
Supply voltage	5.0 ± 0.5 Vdc
Maximum survival voltage	18 Vdc Continuous
Maximum current draw	10 mA
Output at maximum displacement	75% ± 8% of supply voltage
Output at null	50% ± 4% of supply voltage
Output at minimum displacement	23% ± 8% of supply voltage

Top switch environmental

Description	Specification
Operating temperature	-40°C to 80°C [-40°F to 175°F]
Storage temperature	-40°C to 85°C [-40°F to 180°F]
EMI/RFI rating	100 V/m
Mechanical life	6 million cycles

JS1000 grips

Connector pin assignments

Both grip-with-switch options may use either the JS1000 base analog or CAN output option. Refer to the *JS1000 Joystick Base Technical Information*, **BC152886484104** for grip CAN message details and connector pin assignments.

Grip with rocker switch dimensions

Grip with rocker switch dimensions in millimeters [inches].

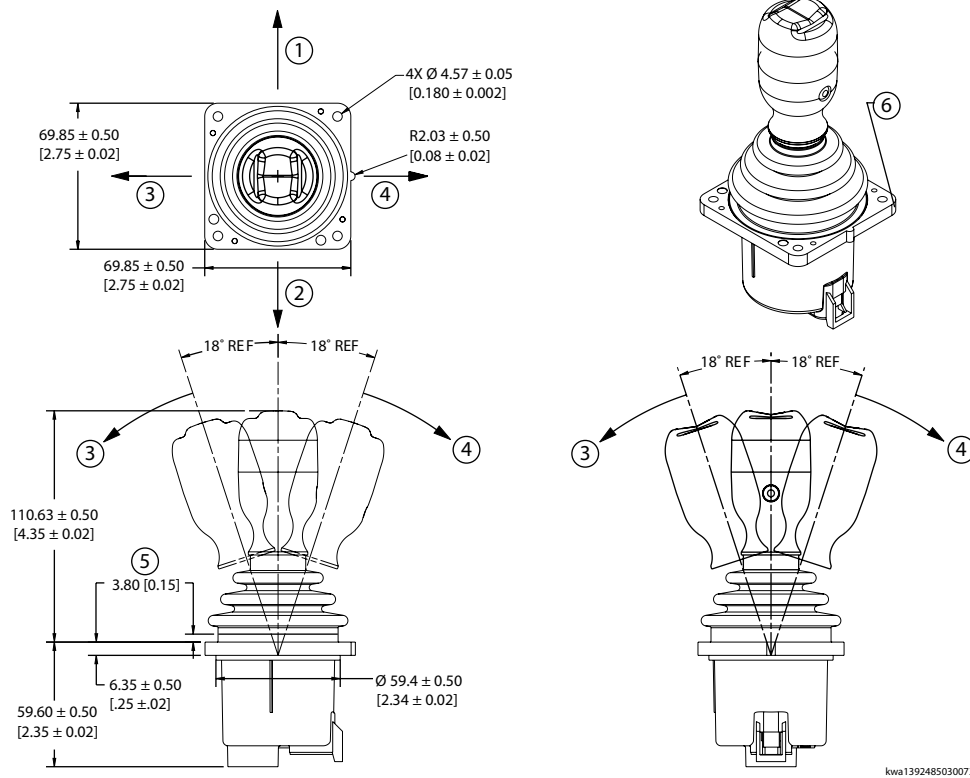

kwa1392485030073

1. Decreasing X
2. Increasing X
3. Decreasing Y
4. Increasing Y
5. Maximum panel feed-through mounting
6. Orientation feature

JS1000 grips

Grip with banana switch dimensions

Grip with banana switch dimensions in millimeters [inches].

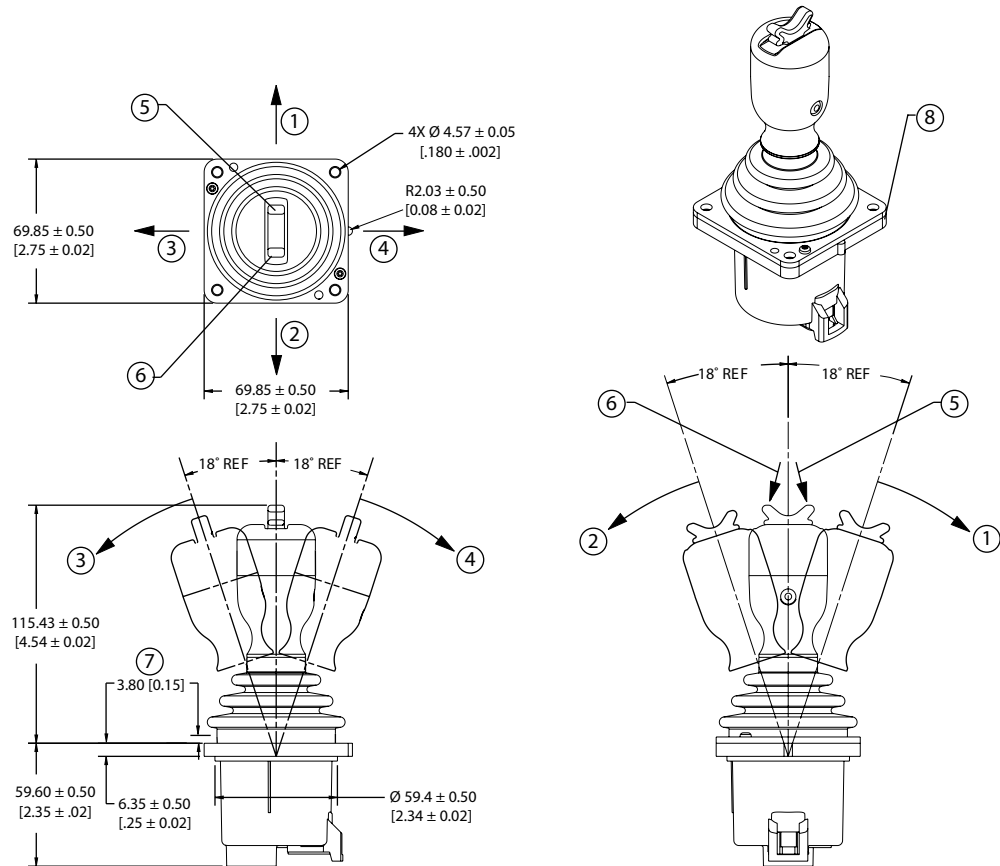

- 1. Decreasing X
- 2. Increasing X
- 3. Decreasing Y
- 4. Increasing Y
- 5. Decreasing switch
- 6. Increasing switch
- 7. Maximum panel feed-through mounting
- 8. Orientation feature

JS1000 grips

Ball grip

Ball grip



Overview

The JS1000 Ball grip provides a simple and comfortable operator control. Manufactured of high impact plastic, the grip is perfectly suited for mobile machine applications requiring only X-Y control and no switch or proportional input options.

Model code nomenclature

Grip and grip options are specified using the Danfoss joystick model code. For grips designed to mate with the JS1000 joystick base, use code positions E2, F, G and J to specify grip properties. Reference [JS1000 base model code](#) on page 6.

The ball grip is designated using only the E2 portion of the code.

Specifications

Environmental

Description	Specification
Operating temperature	-40°C to 80°C [-40°F to 175°F]
Storage temperature	-40°C to 85°C [-40°F to 180°F]
Environmental protection	IP 66, 67

Connector pin assignments

The ball grip has no electrical outputs. It can be mounted on JS1000 bases having either a CAN or analog output. Refer to the *JS1000 Joystick Base Technical Information*, **BC152886484104** for grip CAN message details and connector pin assignments.

JS1000 grips

Dimensions

Ball grip dimensions in millimeters [inches].

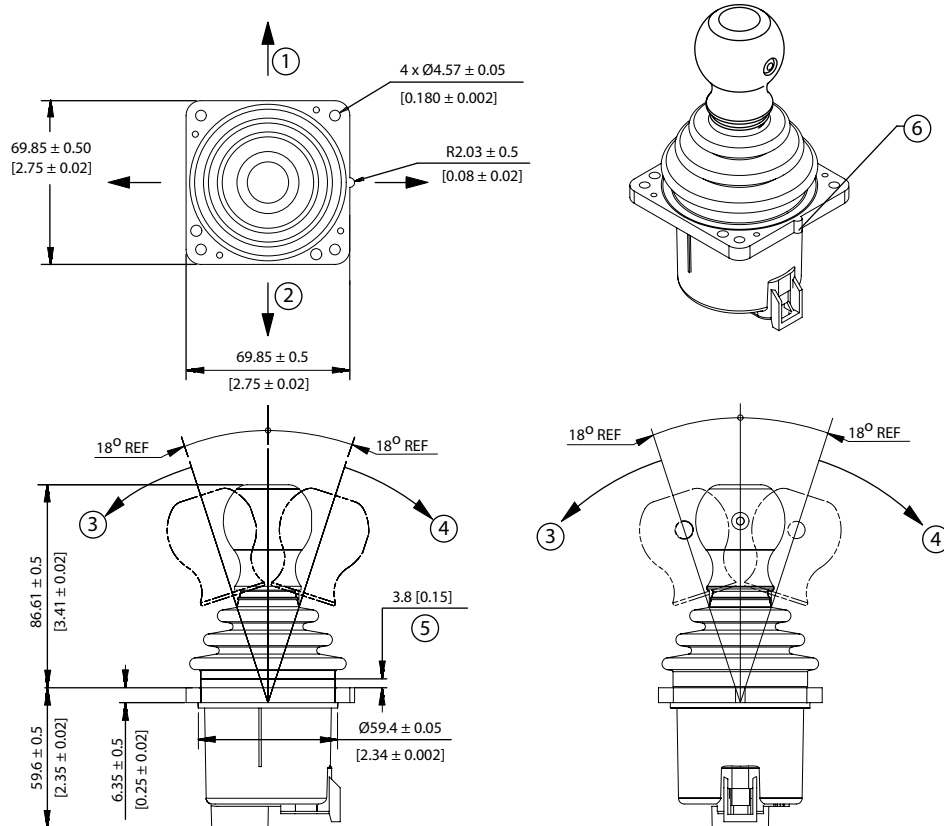

kwa1392485052374

1. Decreasing X
2. Increasing X
3. Decreasing Y
4. Increasing Y
5. Maximum panel feed-through mounting
6. Orientation feature

JS6000 grips

JS6000 base model code

JS6000 product configuration model code example—base part A, B, C, D, E, F and G

A						B		C			D	E	F		G	H				I			J	K	L	M	N	O	P	Q	R	S	
J	S	6	0	0	0	X	Y	H	M	M	H	S	N	L	N	J	3	3	1	A	0	H	0	R	V	N	N	N	N	N	N	N	N

A—Product series

Code	Description
JS6000	Series JS6000 joystick

B—Operational axis options

Code	Description
XY	Bi-directional: X and Y axis
NY	Uni-directional: Y axis only (required for friction-holding)

C—Shaft position sensing and output options

Code	Description
PRR	Potentiometer: single output per axis; $V_o = 10$ to 90% of V_s ; $\pm 1.5^\circ$ neutral threshold
PQQ	Potentiometer: single output per axis; $V_o = 25$ to 75% of V_s ; $\pm 1.5^\circ$ neutral threshold
PSS	Potentiometer: single output per axis; $V_o = 10$ to 90% of V_s ; $\pm 5^\circ$ neutral threshold
PTT	Potentiometer: single output per axis; $V_o = 25$ to 75% of V_s ; $\pm 5^\circ$ neutral threshold
PUU	Potentiometer: dual output per axis; $V_o = 10$ to 90% of V_s ; $\pm 1.5^\circ$ neutral threshold
HMM	Hall effect: dual sensors per axis; $V_s = 5$ VDC; $V_o = 0.5$ to 4.5 VDC
CAN	Hall effect: dual sensors per axis; $V_s = 9$ to 36 VDC; CAN 2.0B communication, 6 pin connector
CPL	Hall effect: dual sensors per axis; $V_s = 9$ to 36 VDC; CAN 2.0B communication, 18 pin connector

D—Centering spring options

Code	Description
H	Heavy force
M	Medium force
L	Light force
F	Friction-hold (position maintained, center detent)

E—Gate pattern options

Code	Description
S	Square, full output at 45 degree

F—Mechanical options

Code	Description
NL	No mechanical option; spring return to center only
FB	Friction-held in Y axis; no X axis; center detent; 1.25 Nm [0.92 lb•ft] friction-hold force; 2.5 Nm [1.66 lb•ft] breakout force

JS6000 grips

F—Mechanical options (continued)

Code	Description
FC	Friction-held in Y axis; no X axis; center detent; 1.25 Nm [0.92 lb-ft] friction-hold force; 3.25 Nm [2.40 lb-ft] breakout force
HC	Friction-held in Y axis; no X axis; center detent; 2.25 Nm [1.66 lb-ft] friction-hold force; 4.0 Nm [2.95 lb-ft] breakout force

G—Direction (microswitch) options

Code	Description
N	No switches
Y	Microswitches installed (analog potentiometer option only)

JS6000 grips model code

JS6000 grip product configuration model code example—grip properties - I, J, K, L, M, N, O, P, Q, R, and S

A				B		C		D	E	F		G	H				I				J	K	L	M	N	O	P	Q	R	S				
1	2	3	4	1	2	3	4	1	2	3	4	1	2	3	4	1	2	3	4															
J	S	6	0	0	0	X	Y	H	M	M	H	S	N	L	N	J	3	3	1	A	0	H	0	R	V	N	N	N	N	N	N	N	N	N

H1—Electrical interface options

Code	Description
S	Analog (voltage output from joystick sensors or switches)
J	CAN, SAE J1939 protocol

H2, 3—CAN Source Address*

Code	Description
NN	None—use with analog outputs when H1 = S
33	Source address = 0x 33
34	Source address = 0x 34
35	Source address = 0x 35
36	Source address = 0x 36

* Consult the factory if additional source addresses are required.

H4—Joystick output type

Code	Description
N	None—use with analog outputs when H1 = S
1	CAN full scale output = 1000 counts

I, J, K—Grip proportional rocker output and style

For grips designed to mate with the JS6000 joystick base, use code positions, I through S to specify grip properties. Refer to [Front plate model code designations](#) on page 25 for rocker switch location examples.

JS6000 grips

I—Grip switch details

I	Code	Description
1	Handle type	
2	Number of buttons	
3	L	Left rocker location (vertical orientation)
	R	Right rocker location (vertical orientation)
	B	Both left and right (vertical orientation)
	H	Horizontal rocker location
	0	No rocker switch
4	T	Top switch
	D	Operator Presence switch
	B	Both top and Operator Presence switch
	0	No top switch, no Operator Presence switch

J—A grip proportional rocker output

Code	Description
R	Potentiometer, 10% to 90% Vs
Q	Potentiometer, 25% to 75% Vs
N	None

K—A grip proportional rocker style

Code	Description
S	Wave style
V	V style
N	None

L, M, N, O, P, Q, R, S—Grip options

For A grips use code positions L, M, N, O, P, Q, R, and S to specify grip button colors.

Grip button position to model code conversion

Grip front plate button position [†]	Corresponding master model code
1	L
2	M
3	N
4	O
5	P
6	Q
7	R
8	S

[†] See [A grip connector pin assignments](#) on page 30.

Grip Button Color Options

Code	Description
R	Red
B	Black [†]

JS6000 grips

Grip Button Color Options (continued)

Code	Description
G	Green [‡]
Y	Yellow [‡]
L	Blue [‡]
N	No pushbutton switch

[‡] The red colored pushbutton switch is considered the default color. There is a five-piece order minimum each time the other color options are ordered.

JS6000 connector pin assignments

JS6000 grip function connector pin assignments for the JS6000 connector that contains grip outputs are dependent on the type of joystick shaft position sensor (potentiometer or Hall) and the electrical output option (analog or CAN) selected for the joystick base. Analog base grip pin assignments are found in [A grip connector pin assignments](#) on page 30 and [MG grip connector pin assignments](#) on page 36 of this manual. Pin assignments for other analog base functions are found in the *JS6000 Joystick Base Technical Information, BC152886483634*.

Grip pin assignments for joystick bases that have analog outputs depend on whether a potentiometer or Hall sensor is used to measure the position of the joystick shaft. If a potentiometer is used, the 12 pin connector on the joystick base is used for grip outputs. If a Hall sensor is used, the 16 pin connector is used for grip outputs.

If the CAN electrical output option is selected, a 6 or 18 pin DEUTSCH connector is provided in the base and input information from the grip is broadcast in a J1939 message format. Refer to the *JS6000 Joystick Base Technical Information, BC152886483634* for details on J1939 CAN grip messages and DEUTSCH connector pin assignments.

JS6000 grips

A grip

A grip



Multi-function grip

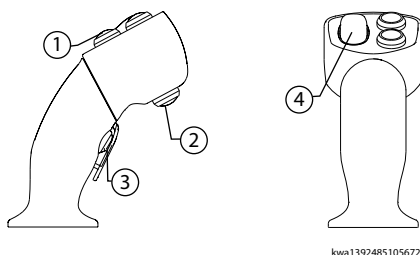

1. Pushbutton switch
2. Top switch
3. Operator Presence switch
4. Left rocker

Overview

The A grip is a multi-function, ambidextrous ergonomic grip designed for a comfortable user interface and maximum functional control. The grip features a modular design that allows switch and proportional rocker location flexibility.

The A grip is available with combinations of up to eight switches and up to two proportional inputs. One of the optional switches can be used to provide an Operator Presence function on the grip. Available button colors are red, black, green, yellow, and blue.

Model code nomenclature

Grip and grip options are specified using the Danfoss joystick model code. For grips designed to mate with the JS6000 joystick base, use code positions I through S to specify grip properties. Reference [JS6000 grips model code](#) on page 20.

Model code for a grip front plate options

I Code	Number of momentary switches— grip front plate	Number, location of proportional rocker switches—grip front plate	Number, location of momentary switches— back of grip
A000	0	0	0
A00T	0	0	T
A00D	0	0	D
A00B	0	0	B
A0L0	0	L	0
A0LD	0	L	D
A0R0	0	R	0
A0RD	0	R	D
A0B0	0	B	0

JS6000 grips

Model code for a grip front plate options (continued)

I Code	Number of momentary switches— grip front plate	Number, location of proportional rocker switches—grip front plate	Number, location of momentary switches— back of grip
A0BD	0	B	D
A0H0	0	H	0
A0HD	0	H	D
A0RB	0	R	B
A0RT	0	R	T
A0LB	0	L	B
A0LT	0	L	T
A100	1	0	0
A10T	1	0	T
A10D	1	0	D
A10B	1	0	B
A1L0	1	L	0
A1R0	1	R	0
A1H0	1	H	0
A1LD	1	L	D
A1RD	1	R	D
A1HD	1	H	D
A1RT	1	R	T
A1LT	1	L	T
A1RB	1	R	B
A1LB	1	L	B
A200	2	0	0
A20T	2	0	T
A20D	2	0	D
A20B	2	0	B
A2L0	2	L	0
A2R0	2	R	0
A2H0	2	H	0
A2LD	2	L	D
A2RD	2	R	D
A2HD	2	H	D
A2RB	2	R	B
A2RT	2	R	T
A2LB	2	L	B
A2LT	2	L	T
A300	3	0	0
A30T	3	0	T
A30D	3	0	D
A30B	3	0	B
A3R0	3	R	0
A3RD	3	R	D

JS6000 grips

Model code for a grip front plate options (continued)

I Code	Number of momentary switches— grip front plate	Number, location of proportional rocker switches—grip front plate	Number, location of momentary switches— back of grip
A3L0	3	L	0
A3LD	3	L	D
A3RT	3	R	T
A3LT	3	L	T
A400	4	0	0
A40T	4	0	T
A40D	4	0	D
A40B	4	0	B
A500	5	0	0
A50D	5	0	D
A50B	5	0	B
A50T	5	0	T
A600	6	0	0
A60D	6	0	D
A60B	6	0	B
A60T	6	0	T

Front plate model code designations

A grip front plate diagram

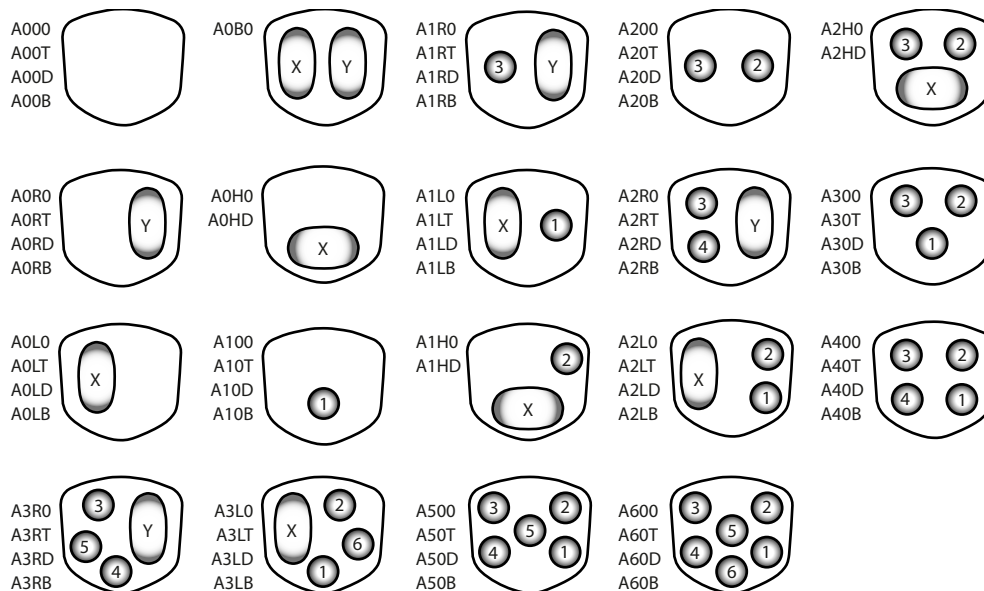

kwa1392485072935

JS6000 grips

Rocker switch profiles

Profile of wave rocker switch option

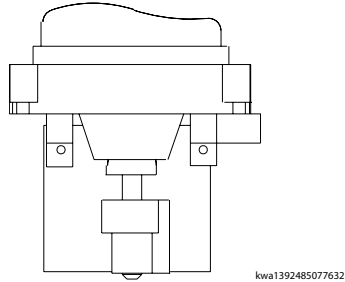

kwa1392485077632

Profile of V rocker switch option

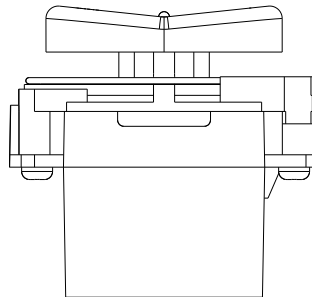

kwa1456156357759

Rocker switch specifications

The optional grip rocker switches use a conductive plastic potentiometer to generate an analog output that is proportional to switch position. The wipers that run across the potentiometer track are driven by the thumb operated rocker mechanism. Rocker switch action is spring return to center.

Mechanical

Description	Specification
Breakout force	5 N [1.12 lbf]
Operating force	15 N [3.37 lbf]
Maximum applied force	50 N [11.24 lbf]
Mechanical angle of movement	$\pm 12^\circ$
Electrical angle of movement	$\pm 9^\circ$
Expected life	>5 million operations

Environmental

Description	Specification
Operating temperature	-40°C to 70°C [-40°F to 158°F]
Storage temperature	-40°C to 80°C [-40°F to 176°F]
Environmental sealing	IP 65

JS6000 grips

Electrical

Description	Specification
Maximum load current	Potentiometer wiper* Directional switches: 200 mA
Maximum power dissipation	0.25 W at 25° C [77° F]
Output voltage ranges	25 to 75% Vs 10 to 90% Vs
Center tap voltage	50% Vs ± 2%
Center tap angle	1.5° either side of center
Directional switch operating angle	2.5° either side of center
Directional switch maximum supply voltage	36 Vdc
Directional switch current rating	5 mA

* The rocker is only to be used as a potentiometer and not as a variable resistor. Wiper load must be resistance greater than 100 kΩ.

- Center tap has an angle of $\pm 1.5^\circ$
- 50% of the Vs is supplied at the center position
- The track also has a directional switch with a center off switch
- The direction switch changes state after a movement of 2.5° in each direction
- The switch current rating is 5 mA

Rocker switch wiring details

Left rocker

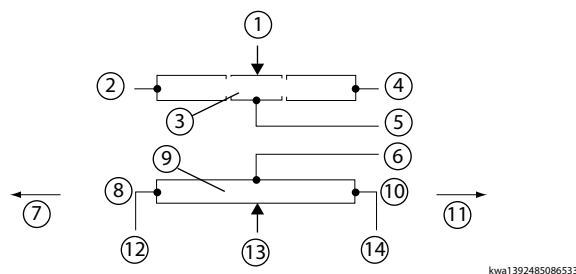

- | | |
|------------------------|----------------------------|
| 1. Black | 2. Blue/orange |
| 3. Switch track | 4. Green |
| 5. Left blank | 6. Center tap (yellow/red) |
| 7. Forwards | 8. 0 V |
| 9. Potentiometer track | 10. 5 V |
| 11. Backwards | 12. White/red (V+) |
| 13. Pink | 14. Pink/gray (V-) |

JS6000 grips

Right rocker

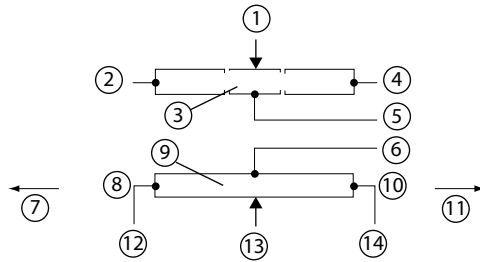

kwa1392485086533

- | | |
|------------------------|----------------------------|
| 1. Black | 2. Blue |
| 3. Switch track | 4. Yellow |
| 5. Left blank | 6. Center tap (yellow/red) |
| 7. Backwards | 8. 5 V |
| 9. Potentiometer track | 10. 0 V |
| 11. Forwards | 12. Pink/gray (V+) |
| 13. White | 14. White/red (V-) |

Horizontal rocker

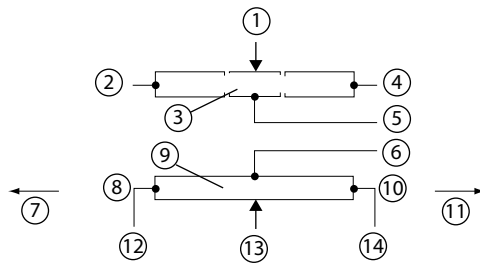

kwa1392485086533

- | | |
|------------------------|----------------------------|
| 1. Black | 2. Blue |
| 3. Switch track | 4. Green |
| 5. Left blank | 6. Center tap (yellow/red) |
| 7. Left | 8. 0 V |
| 9. Potentiometer track | 10. 5 V |
| 11. Right | 12. White/red (V+) |
| 13. Pink | 14. Pink/gray (V-) |

Pushbutton specifications

Electrical

Description	Specification
Switch action	Momentary
Switch type	Single pole, NO
Contact rating	200 mA at 50 Vdc - person present switch
	100 mA at 50 Vdc - top and front plate switches
Contact resistance	50 MΩ maximum
Mechanical life	1 million cycles

JS6000 grips

Environmental

Description	Specification
Operating temperature	-40°F to 70°C [-40°C to 158°F]
Storage temperature	-40°F to 80°C [-40°C to 176°F]
Environmental sealing	IP 66
Operating force	3 N [0.674 lbf]

Pushbutton wiring details

Pushbutton switches

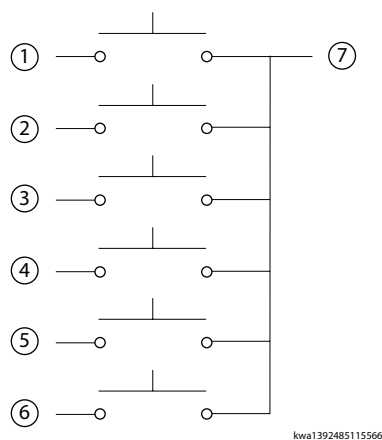

- 1.** 1 Blue
- 2.** 2 Yellow
- 3.** 3 Yellow/Orange
- 4.** 4 Green
- 5.** 5 Red
- 6.** 6 Violet
- 7.** Black

Top switch

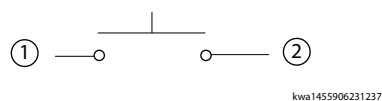

- 1.** Pink with marker sleeve
- 2.** Black

Operator Presence switch

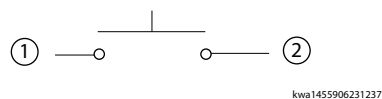

JS6000 grips

1. Red/Green
2. Black/White

A grip connector pin assignments

Warning

Potential uncommanded machine movement. JS6000 base and grip pinout specifications are a function of joystick base measurement sensor type and electrical output (analog or CAN). For joysticks with analog output, the pinout assignments for the 12 and 16 pin connectors depend on whether a potentiometer or Hall sensor is used to measure the position of the joystick shaft. If a potentiometer sensor is used, the 12 pin connector is used for grip outputs. If a Hall sensor is used, the 16 pin connector is used for grip outputs and pins 13 through 16 are not used. Refer to the [Rocker switch specifications](#) on page 26 for information regarding the switch nomenclature used below. Refer to [Front plate model code designations](#) on page 25 for information regarding the location nomenclature for push button switches.

- Pins 13 to 16 are not used on the 16 pin connector
- Blank = Pin not used

A grip button position designations

Code	Pin number															
	1	2	3	4	5	6	7	8	9	10	11	12	13	14	15	16
A000																
A00T					Top switch						Common					
A00D								Operator presence			Common	Operator presence				
A00B					Top switch			Operator presence			Common	Operator presence				
A0L0	Switch out L	Switch out L			VoutL	Center tap	V+				V-	Common				
A0LD	Switch out L	Switch out L			VoutL	Center tap	V+	Operator presence			V-	Common	Operator presence			
A0LT	Switch out L	Switch out L			VoutL	Center tap	V+		Top switch		V-	Common				
A0LB	Switch out L	Switch out L			VoutL	Center tap	V+	Operator presence	Top switch		V-	Common	Operator presence			
A0R0			Switch out R	Switch out R		Center tap	V+			VoutR	V-	Common				
A0RD			Switch out R	Switch out R		Center tap	V+	Operator presence		VoutR	V-	Common	Operator presence			
A0B0	Switch out L	Switch out L	Switch out R	Switch out R	VoutL	Center tap	V+			VoutR	V-	Common				
A0BD	Switch out L	Switch out L	Switch out R	Switch out R	VoutL	Center tap	V+	Operator presence		VoutR	V-	Common	Operator presence			
A0H0	Switch out H			Switch out H	VoutH	Center Tap	V+				V-	Common				
A0HD	Switch out H			Switch out H	VoutH	Centertap	V+	Operator presence			V-	Common	Operator presence			
A0RT			Switch out R	Switch out R	Top switch	Center tap	V+			VoutR	V-	Common				
A100				PB1							Common					

JS6000 grips

A grip button position designations (continued)

Code	Pin number															
	1	2	3	4	5	6	7	8	9	10	11	12	13	14	15	16
A10T				PB1	Top switch						Common					
A10D				PB1				Operator presence			Common	Operator presence				
A10B				PB1	Top switch			Operator presence			Common	Operator presence				
A1L0	Switch out L	Switch out L		PB1	VoutL	Center tap	V+			V-	Common					
A1R0		PB3	Switch out R	Switch out R		Center tap	V+		VoutR	V-	Common					
A1H0	Switch out H		PB2	Switch out H	VoutH	Center top	V+			V-	Common					
A1LD	Switch out L	Switch out L		PB1	VoutL	Center tap	V+	Operator presence		V-	Common	Operator presence				
A1RD		PB3	Switch out R	Switch out R		Center tap	V+	Operator presence	VoutR	V-	Common	Operator presence				
A1HD	Switch out H		PB2	Switch out H	VoutH	Center top	V+	Operator presence		V-	Common	Operator presence				
A1RT		PB3	Switch out R	Switch out R	Top switch	Center tap	V+		VoutR	V-	Common					
A1LT	Switch out L	Switch out L		PB1	VoutL	Center tap	V+		Top switch	V-	Common					
A1RB		PB3	Switch out R	Switch out R	Top switch	Center tap	V+	Operator presence	VoutR	V-	Common	Operator presence				
A1LB	Switch out L	Switch out L		PB1	VoutL	Center tap	V+	Operator presence	Top switch	V-	Common	Operator presence				
A200		PB3	PB2								Common					
A20T		PB3	PB2		Top switch						Common					
A20D		PB3	PB2					Operator presence			Common	Operator presence				
A20B		PB3	PB2		Top switch			Operator presence			Common	Operator presence				
A2L0	Switch out L	Switch out L	PB2	PB1	VoutL	Center tap	V+			V-	Common					
A2R0	PB4	PB3	Switch out R	Switch out R		Center tap	V+		VoutR	V-	Common					
A2H0	Switch out H	PB3	PB2	Switch out H	VoutH	Center tap	V+			V-	Common					
A2LD	Switch out L	Switch out L	PB2	PB1	VoutL	Center tap	V+	Operator presence		V-	Common	Operator presence				
A2RD	PB4	PB3	Switch out R	Switch out R		Center tap	V+	Operator presence	VoutR	V-	Common	Operator presence				
A2HD	Switch out H	PB3	PB2	Switch out H	VoutH	Center tap	V+	Operator presence		V-	Common	Operator presence				
A2RB	PB4	PB3	Switch out R	Switch out R	Top switch	Center tap	V+	Operator presence	VoutR	V-	Common	Operator presence				

JS6000 grips

A grip button position designations (continued)

Code	Pin number															
	1	2	3	4	5	6	7	8	9	10	11	12	13	14	15	16
A2RT	PB4	PB3	Switch out R	Switch out R	Top switch	Center tap	V+		VoutR	V-	Common					
A2LB	Switch out L	Switch out L	PB2	PB1	VoutL	Center tap	V+	Operator presence	Top switch	V-	Common	Operator presence				
A2LT	Switch out L	Switch out L	PB2	PB1	VoutL	Center tap	V+		Top switch	V-	Common					
A300		PB3	PB2	PB1							Common					
A30T		PB3	PB2	PB1	Top switch						Common					
A30D		PB3	PB2	PB1				Operator presence			Common	Operator presence				
A30B		PB3	PB2	PB1	Top switch			Operator presence			Common	Operator presence				
A3RO	PB4	PB3	Switch out R	Switch out R		Center tap	V+	PB5	VoutR	V-	Common					
A3RD	PB4	PB3	Switch out R	Switch out R	PB5	Center tap	V+	Operator presence	VoutR	V-	Common	Operator presence				
A3LO	Switch out L	Switch out L	PB2	PB1	VoutL	Center tap	V+		PB6	V-	Common					
A3LD	Switch out L	Switch out L	PB2	PB1	VoutL	Center tap	V+	Operator presence	PB6	V-	Common	Operator presence				
A3RT	PB4	PB3	Switch out R	Switch out R	Top switch	Center tap	V+	PB5	VoutR	V-	Common					
A3LT	Switch out L	Switch out L	PB2	PB1	VoutL	Center tap	V+	PB6	Top switch	V-	Common					
A400	PB4	PB3	PB2	PB1							Common					
A40T	PB4	PB3	PB2	PB1	Top switch						Common					
A40D	PB4	PB3	PB2	PB1				Operator presence			Common	Operator presence				
A40B	PB4	PB3	PB2	PB1	Top switch			Operator presence			Common	Operator presence				
A500	PB4	PB3	PB2	PB1				PB5			Common					
A50D	PB4	PB3	PB2	PB1	PB5			Operator presence			Common	Operator presence				
A50B	PB4	PB3	PB2	PB1	Top switch			Operator presence	PB5		Common	Operator presence				
A50T	PB4	PB3	PB2	PB1	Top switch			PB5			Common					
A600	PB4	PB3	PB2	PB1	PB5				PB6		Common					
A60D	PB4	PB3	PB2	PB1	PB5			Operator presence	PB6		Common	Operator presence				
A60B	PB4	PB3	PB2	PB1	Top switch	PB5		Operator presence	PB6		Common	Operator presence				
A60T	PB4	PB3	PB2	PB1	Top switch			PB5	PB6		Common					

JS6000 grips

Dimensions

A grip dimensions in millimeters [inches].

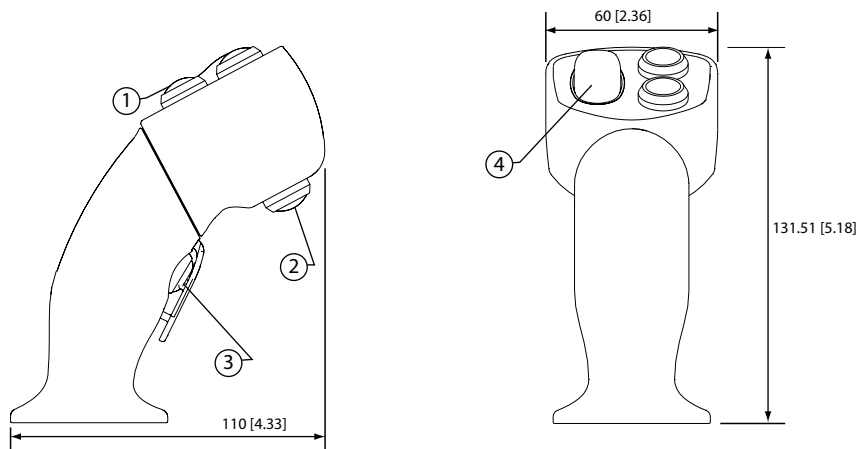

- 1. Pushbutton switch
- 2. Top switch
- 3. Operator Presence switch
- 4. Left rocker

kwa1392485122295

JS6000 grips

MG grip

MG grip



Overview

The MG multi-function grip is designed to provide an ergonomic solution to grip applications requiring an operator presence function. The profile of the MG grip ensures that the operators fingers are always close to the buttons to minimize operator fatigue and maximize functional control. An optional hand rest feature is also available to further minimize operator fatigue and provide additional protection for the joystick boot.

The grip is available with or without an operator presence lever switch, as well as up to two low current switches at the top of the grip. If two top switches are present, they are actuated through a rocker assembly.

0 switch option with Operator Presence lever

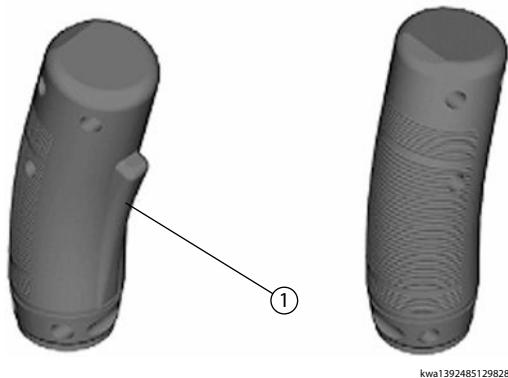

1. Operator presence lever

1 switch option with Operator Presence lever

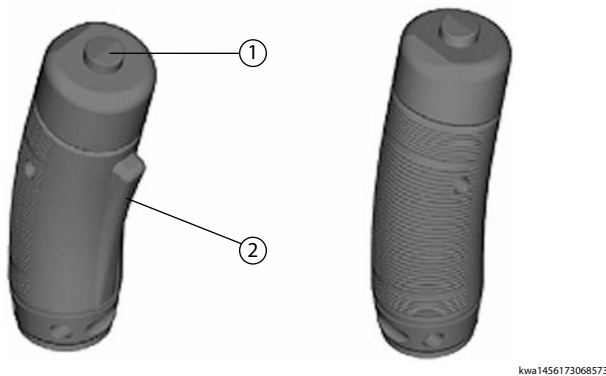

**1. Switch 1 position
 2. Operator presence lever**

JS6000 grips

2 switch option with Operator Presence lever

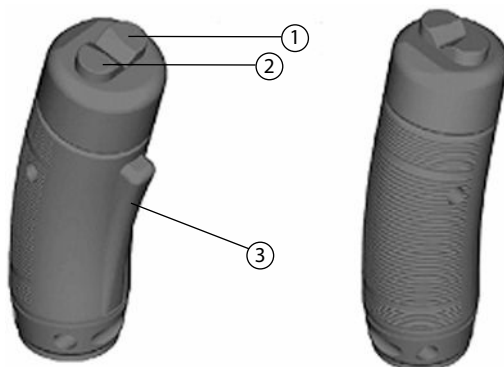

kwa1456173104294

1. Switch 1 position
2. Switch 2 position
3. Operator presence lever

Grip with hand rest option

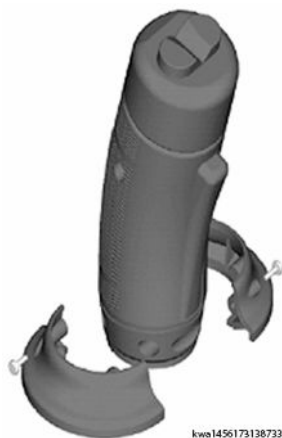

kwa1456173138733

Model code nomenclature

Grip and grip options are specified using the Danfoss joystick model code. For grips designed to mate with the JS6000 joystick base, use code positions I, J and K to specify grip properties. Reference [JS6000 base model code](#) on page 19.

[MG grip model codes do not use model code positions J through S.](#)

Model code for MG grip switch positions

Code	Switch position*	Operator presence lever	Hand rest
MG00	No switches	No lever	No hand rest
MG01	Switch 1	No lever	No hand rest
MG02	Switch 1, 2	No lever	No hand rest
MG03	Switch 1,2	Included	No hand rest
MG04	Switch 1,2	Included	Included
MG05	Switch 1	Included	Included
MG06	Switch 1,2	No lever	Included
MG07	Switch 1	No lever	Included

JS6000 grips

Model code for MG grip switch positions (continued)

Code	Switch position*	Operator presence lever	Hand rest
MG08	Switch 1	Included	No hand rest
MG09	No switches	Included	Included
MG10	No switches	No lever	Included
MG11	No switches	Included	No hand rest

* Refer to [Dimensions](#) on page 39, for definition of switch locations.

Specifications

Electrical

Description	Specification
Contact resistance	50Ω
Contact bounce	1 ms
Insulation resistance	>100 MΩ at 50 Vdc
Dielectric strength	500 V (50 Hz, 1 min.)
Switching current	Max: 100 mA Min : 10 μA
Switching voltage	Max: 30 Vdc Min: 2 Vdc
Electrical life	1 million cycles at maximum voltage

Environmental

Description	Specification
Operating temperature	-25°C to 75°C [-13°F to 167°F]
Storage temperature	-30°C to 80°C [-22°F to 178°F]
Ingress protection	IP 67 (operator presence lever may not operate in icing conditions)

MG grip connector pin assignments

Warning

Potential uncommanded machine movement. JS6000 base and grip connector pin assignments are a function of joystick base shaft measurement sensor type and base electrical output (analog or CAN). For joysticks with analog output, the pin assignments for the 12 and 16 pin base connectors depend on whether a potentiometer or Hall sensor is used to measure the position of the joystick shaft. If a potentiometer sensor is used, the 12 pin connector is used for grip outputs. If a Hall sensor is used, the 16 pin connector is used for grip outputs.

12 pin connector MG grip pin assignments

Pin number	Description
1	Not used
2	Not used
3	Switch 2
4	Operator presence
5	Operator presence

JS6000 grips

12 pin connector MG grip pin assignments (continued)

Pin number	Description
6	Switch 1
7	Not used
8	Not used
9	Not used
10	Not used
11	Not used
12	Common for switch 1, 2

16 pin connector MG pin assignments

Pin number	Description
1	Not used
2	Not used
3	Switch 2
4	Operator presence
5	Operator presence
6	Switch 1
7	Not used
8	Not used
9	Not used
10	Not used
11	Not used
12	Common for switch 1,2
13	Not used
14	Not used
15	Not used
16	Not used

Switch wiring details

1 switch option

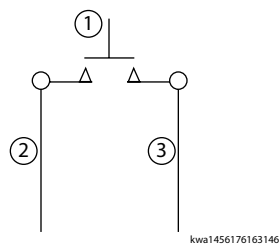

1. Switch 1
2. Blue
3. Black

JS6000 grips

2 switch option

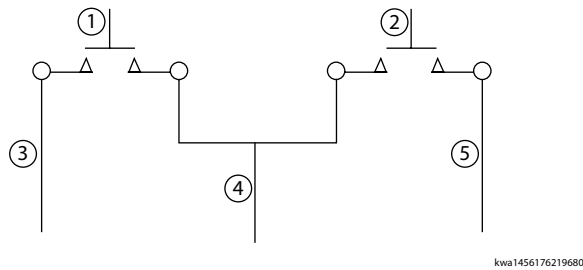

- 1.** Switch 1
- 2.** Switch 2
- 3.** Blue
- 4.** Black
- 5.** Green

Operator Presence switch

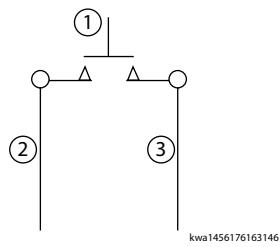

- 1.** Operator Presence switch
- 2.** Yellow
- 3.** Blue/orange

JS6000 grips

Dimensions

MG grip dimensions in millimeters [inches].

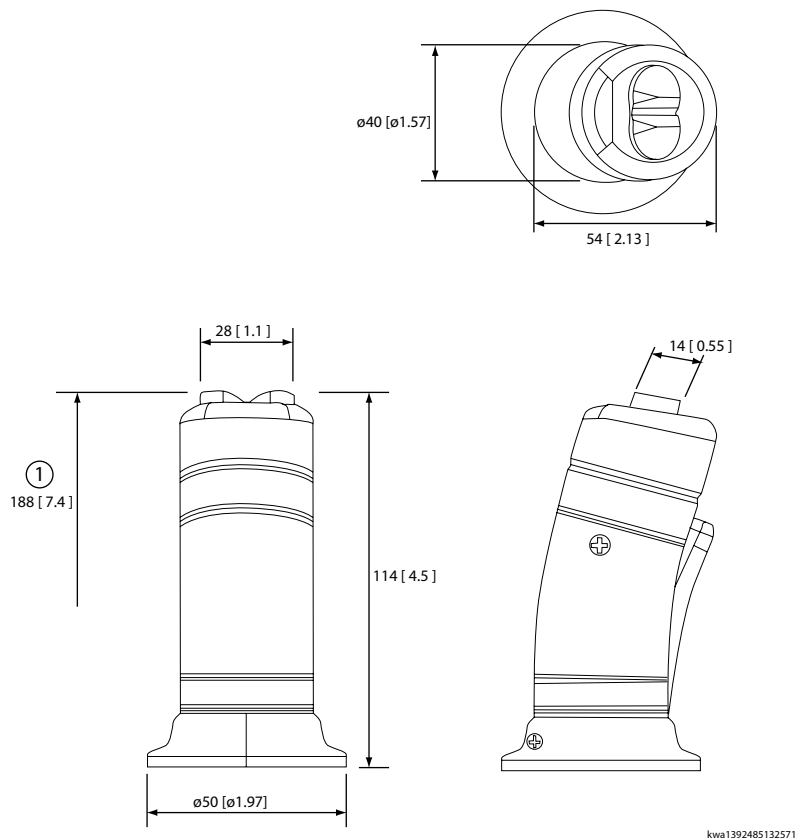

JS6000 grips

HKN grip

HKN grip



Overview

The HKN grip is a plain, high impact plastic knob grip that has no electrical interface. It is designed to provide a comfortable grip for extended machine operation.

Model code

Grip and grip options are specified using the Danfoss joystick model code. For grips designed to mate with the JS6000 joystick base, use code positions I, through S to specify grip properties. Reference [JS6000 base model code](#) on page 19 and [JS6000 grips model code](#) on page 20.

The HKN does not use master model code positions J through S.

The master model code for HKN grips is HKN0.

Environmental specifications

Environmental

Description	Specification
Operating temperature	-40°C to 80°C (-40°F to 176°F)
Storage temperature	-40°C to 85°C (-40°F to 185°F)
Environmental sealing	IP 66

Dimensions

HKN grip dimensions

Maximum height above flange	Maximum diameter
45 mm [1.76 in]	34.6 mm [1.36 in]

Service parts

JS1000 service part availability

Service part availability for JS1000 joystick is a function of joystick base and grip specifications. Refer to the *JS1000 Base Technical Information*, **BC152886484104** for mating connector part information. Refer to the table below for service part information.

JS1000 joystick grip and base service parts

Grip type	Part description	Replacement part ordering number
JS1000 ball grip	Boot	11112055
	Ball grip	10101913
	Grip fastening screw	10101782
JS1000 grip with switch, rocker and banana	Rocker switch cover	10103337
	Banana switch cover	10101816
JS1000 PRO grip	No replacement parts available	

Products we offer:

- Cartridge valves
- DCV directional control valves
- Electric converters
- Electric machines
- Electric motors
- Gear motors
- Gear pumps
- Hydraulic integrated circuits (HICs)
- Hydrostatic motors
- Hydrostatic pumps
- Orbital motors
- PLUS+1® controllers
- PLUS+1® displays
- PLUS+1® joysticks and pedals
- PLUS+1® operator interfaces
- PLUS+1® sensors
- PLUS+1® software
- PLUS+1® software services, support and training
- Position controls and sensors
- PVG proportional valves
- Steering components and systems
- Telematics

Danfoss Power Solutions is a global manufacturer and supplier of high-quality hydraulic and electric components. We specialize in providing state-of-the-art technology and solutions that excel in the harsh operating conditions of the mobile off-highway market as well as the marine sector. Building on our extensive applications expertise, we work closely with you to ensure exceptional performance for a broad range of applications. We help you and other customers around the world speed up system development, reduce costs and bring vehicles and vessels to market faster.

Danfoss Power Solutions – your strongest partner in mobile hydraulics and mobile electrification.

Go to www.danfoss.com for further product information.

We offer you expert worldwide support for ensuring the best possible solutions for outstanding performance. And with an extensive network of Global Service Partners, we also provide you with comprehensive global service for all of our components.

Local address:

Hydro-Gear

www.hydro-gear.com

Daikin-Sauer-Danfoss

www.daikin-sauer-danfoss.com

**Danfoss
Power Solutions (US) Company**
2800 East 13th Street
Ames, IA 50010, USA
Phone: +1 515 239 6000

**Danfoss
Power Solutions GmbH & Co. OHG**
Krokamp 35
D-24539 Neumünster, Germany
Phone: +49 4321 871 0

**Danfoss
Power Solutions ApS**
Nordborgvej 81
DK-6430 Nordborg, Denmark
Phone: +45 7488 2222

**Danfoss
Power Solutions Trading
(Shanghai) Co., Ltd.**
Building #22, No. 1000 Jin Hai Rd
Jin Qiao, Pudong New District
Shanghai, China 201206
Phone: +86 21 2080 6201

Danfoss can accept no responsibility for possible errors in catalogues, brochures and other printed material. Danfoss reserves the right to alter its products without notice. This also applies to products already on order provided that such alterations can be made without subsequent changes being necessary in specifications already agreed. All trademarks in this material are property of the respective companies. Danfoss and the Danfoss logotype are trademarks of Danfoss A/S. All rights reserved.