

**PROPORTIONAL 4-WAY CONTROL VALVES
SOLENOID OPERATED – CETOP 03
TYPE HD3 - PS - ***

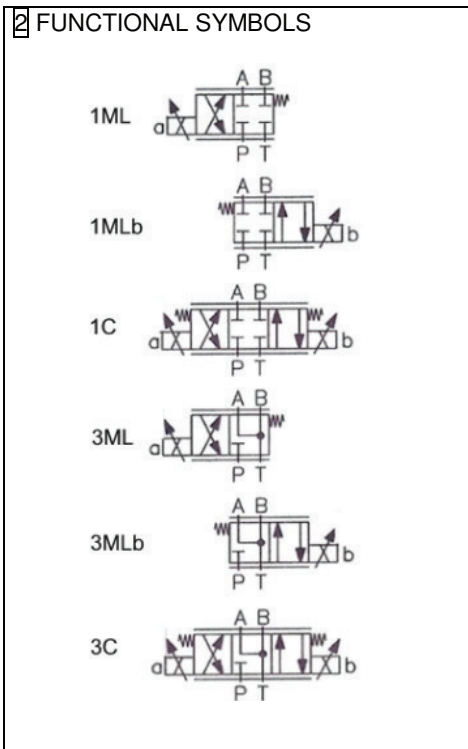
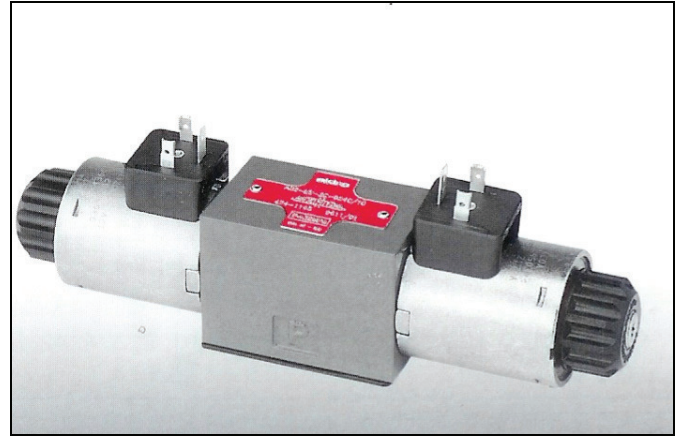
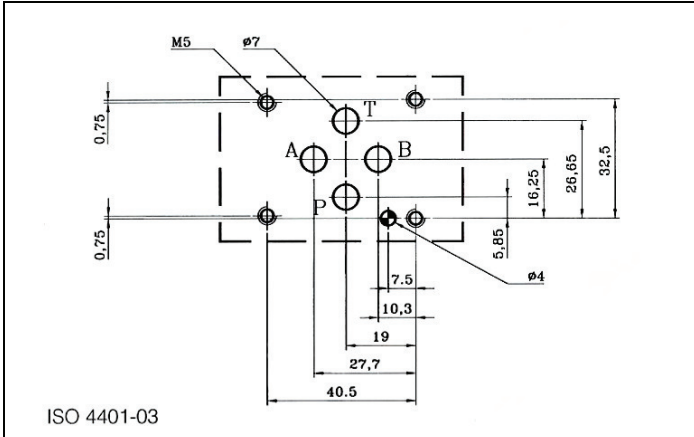

- 1 HOW TO READ THE MODEL CODE FOR VALVES HD3 – PS - ***
- HD3 - PS - (1) (P) - (C) - ** - (R2) / 10**
- | | | | | | | | |
|---|------|-------|-------|-------|------|--------|------|
| ① | ② | ③ | ④ | ⑤ | ⑥ | ⑦ | ⑧ |
| ① HD3 | ② PS | ③ (1) | ④ (P) | ⑤ (C) | ⑥ ** | ⑦ (R2) | ⑧ 10 |
| : 4-way directional valve Cetop 03 – Pressure 32 Mpa (320 bar) | | | | | | | |
| : Proportional electric control | | | | | | | |
| : Functional spool type (see 2 7) | | | | | | | |
| 1 : closed center (P, A, B, T blocked) | | | | | | | |
| 3 : P blocked, A, B, T connected | | | | | | | |
| : Spool nominal flow – see 4 | | | | | | | |
| P : 32 l/min with ΔP = 1 Mpa (10 bar) (PA+BT or PB+AT) | | | | | | | |
| R : 16 l/min with ΔP = 1 Mpa (10 bar) (PA+BT or PB+AT) | | | | | | | |
| 05 : 05 l/min with ΔP = 1 Mpa (10 bar) (PA+BT or PB+AT) | | | | | | | |
| D : differential Qb = 2Qa: 32/16 l/min with ΔP = 1 Mpa (10 bar) | | | | | | | |
| : Solenoid(s) and springs arrangements – see 7 | | | | | | | |
| C : 2 sol., spool is springs centred | | | | | | | |
| ML : 1 sol. (“a”) spool is centred + 1 end position | | | | | | | |
| MLb : 1 sol. (“b”) spool is centred + 1 end position | | | | | | | |
| : Options and variants: | | | | | | | |
| K : extended manual overrides – see 9 | | | | | | | |
| AK : extended manual overrides with air bleeding valves– see 9 | | | | | | | |
| ZC : zinc plated valves – see 13 | | | | | | | |
| : Type of coil(s) and supply voltages – see 6 14 | | | | | | | |
| R2 : R= 2,3 Ω standard for V12DC; R3 : R= 4,5 Ω | | | | | | | |
| R4 : R=13,4 Ω standard for V24DC; R5 : R=18,6 Ω | | | | | | | |
| : Design number (progressive) of the valve. | | | | | | | |

3 DESCRIPTION

The spool ⑫ shifts in to the valves body ⑪ subject to the action of springs ⑬ and proportional solenoid ①.

Spool ⑫, depending from its shape and its position in the valves body ⑪, opens and/or closes passages between P, A, B, T ports, thus controlling the direction and the rate of the hydraulic flow. Solenoid ① is energized by electric current flowing-in through cables; in case of electric cut-offs, the spool can be manually shifted by acting on the emergency pins ⑤, located at the end of the solenoids and accessible through the retaining nuts ⑩.

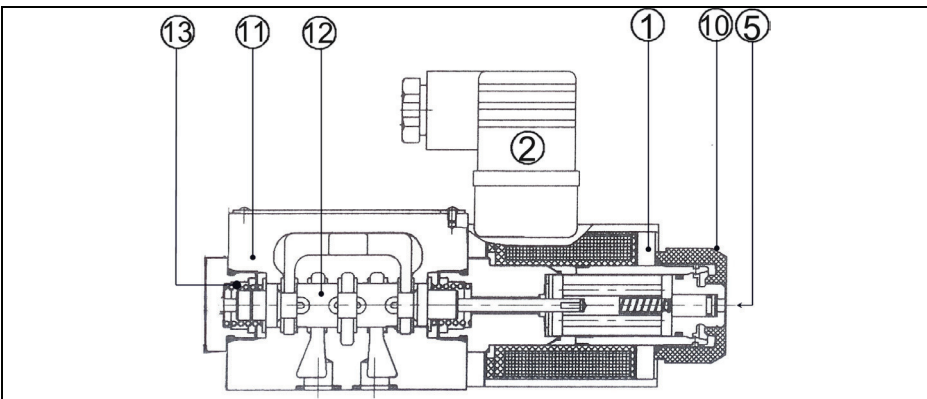

4 TYPICAL DIAGRAMS

Typical flow curves of valves HD3 – PS – *, with spools type P, R, 05 – see [1], in standard configuration measured with mineral oil at 36 cSt and at 50°C at $\Delta P=01$ Mpa (10 bar) for flow $P \rightarrow B$ $A \rightarrow T$

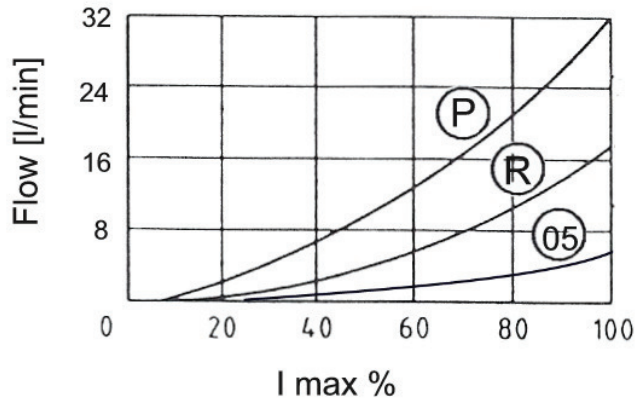

5 TECHNICAL DATA

Nominal flow rates	5, 16, 32 l/min – see [1]
Maximum nominal pressure (P,A,B)	32 Mpa (320 bar)
Maximum pressure at T port	16 Mpa (160 bar)
Maximum rec. Pressure drops	10 Mpa (100 bar) see [8]
Electric characteristics	See [6]
Protection	DIN 40050 IP 67
Duty cycle	100%
Service life	$\geq 10^7$ cycles
Dimensions	See [10]
Installation	See [11] [14]
Mass	Approx 1,6 / 2,1 kg.

7 SPOOL IDENTIFICATION AND NOMINAL FLOW RATES

Nominal Flow rate 5 l/min	
	HD3-PS-105ML-R*
	HD3-PS-305ML-R*
	HD3-PS-105MLb-R*
	HD3-PS-305MLb-R*
	HD3-PS-105C-R*
	HD3-PS-305C-R*
Nominal Flow rate 16 l/min	
	HD3-PS-1RML-R*
	HD3-PS-3RML-R*
	HD3-PS-1RMLb-R*
	HD3-PS-3RMLb-R*
	HD3-PS-1RC-R*
	HD3-PS-3RC-R*
Nominal Flow rate 32 l/min	
	HD3-PS-1PML-R*
	HD3-PS-3PML-R*
	HD3-PS-1PMLb-R*
	HD3-PS-3PMLb-R*
	HD3-PS-1PC-R*
	HD3-PS-3PC-R*
Differential flow: $Q_b=2Q_a$ (example $P \rightarrow B=32$ l/min and $A \rightarrow T=16$ l/min)	
	HD3-PS-1DC-R*
	HD3-PS-3DC-R*

6 ELECTRIC CHARACTERISTICS

Valves type HD3-PS-* are operated by proportional solenoids that are rated for an average max power of 13,5 w.

The values of nominal max. current are:
 for coils type R2 (2,3 Ω): I max = 2,4 A
 R3 (4,5 Ω): I max = 1,7 A
 R4 (13,4 Ω): I max = 1,0 A
 R5 (18,6 Ω): I max = 0,85 A

Currents to hydraulic proportional valves are normally supplied by an electronic driver based on PWM mode of operation, capable of full control of min and max values of current for drivers type UED-M15 – see [14].

8 FLOW RATES AND PRESSURE DIFFERENTIAL.

For a given ΔP on a given valve the flow rates are proportional to the driving current (see [4]); for a given driving current on a given valve, the flow rates increase with the increasing of the ΔP up to certain limits. Typical limit curves are:

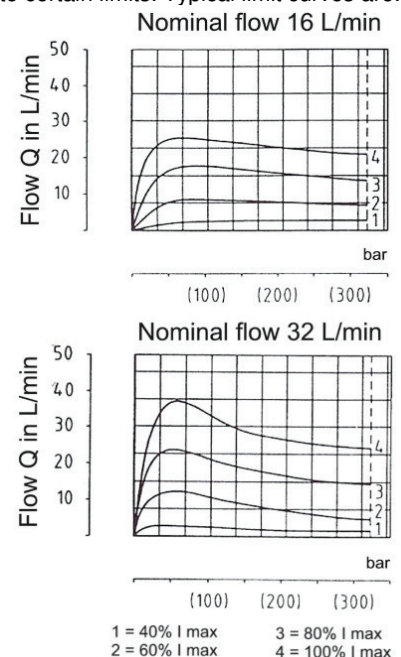

11 INSTALLATION

All valves HD3 - * conform with ISO and CETOP specifications for mounting surface dimensions (see also front page) and for valves height. When assembled to its mounting plate valve HD3 - * must be fastened with 4 bolts M5 X 45 mm (or M5 x ** according to the number of modules) tightened at 8 Nm torque. Of special interest is the mounting of pressure compensator modules with HD3-P proportional valves – see **15**. Leakage between valve and mounting surface is prevented by the positive compression on their seats of 4 seals of QUAD/O Ring type 9,25x1,68x1,68.

12 HYDRAULIC FLUIDS

Seals and materials used on standard valves HD3 - * are fully compatible with hydraulic fluids of mineral oil base, upgraded with antifoaming and anti-oxidizing agents. The hydraulic fluid must be kept clean and filtered to ISO 4406 class 19/17/14, or better, and used in a recommended viscosity range from 10 cSt to 60 cSt.

13 VERSION “ZC”: ZINC PLATED VALVES

Solenoid valves according to “ZC” version have central body zinc plated and protected against every type of corrosion due to saline ambiance or other aggressive chemicals. Zinc thickness are on the valve body: 10-15 µm; and 8/12 µm on solenoids.

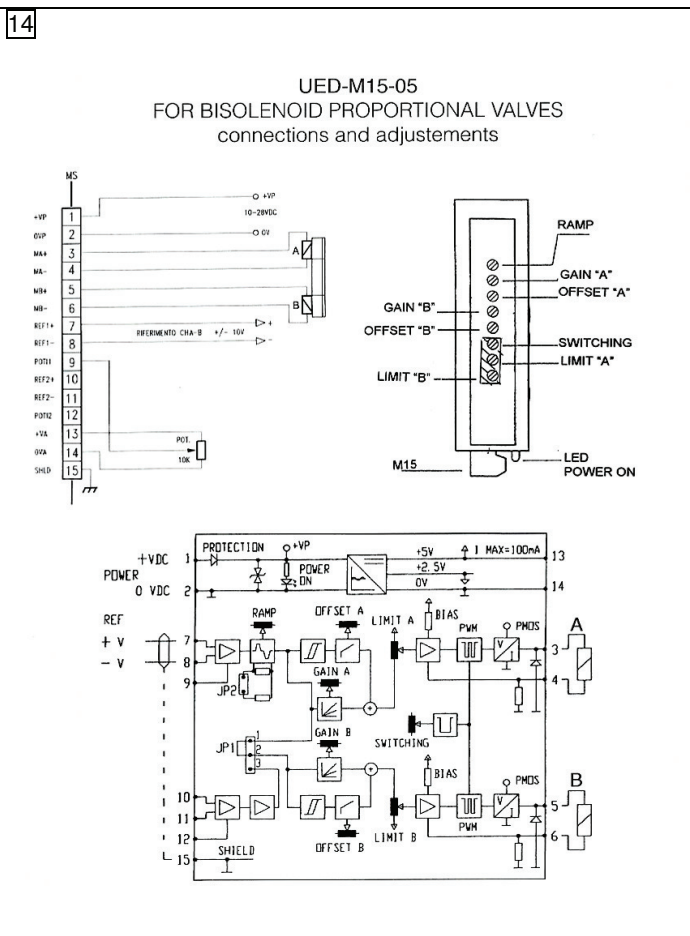

14 CHARACTERISTICS OF STANDARD UED-M15-**

See table ED-M15.
Voltage supply: 10 to 28V DC.
Max ripple: $\pm 10\%$ V supply.
Currents: limit “A” = 2,5 A
 limit “B” = 2,5 A
 bias = 50 mA
Offset “A”: 0 to 50% of limit “A”
Offset “B”: 0 to 50% of limit “B”
Switching: dither frequency 110Hz
Auxiliary V: VR=5V $\pm 1\%$ (max 100 Ma)
Ref. signals:
UED-M15-01 and 11 : 0 \rightarrow +10V (or 2,5V \rightarrow +5V)
UED-M15-05 : -10V \leftarrow 0 \rightarrow +10V (or 0 \leftarrow 2,5 \rightarrow +5V)
Ramp time:
From 0,02 sec to 5 sec
Gain “A”:
Scale from 0,25A/V to “0” A/V (or from 1 A/V to “0” A/V)
Gain “B”:
Scale from 0,25A/V to “0” A/V (or from 1 A/V to “0” A/V)
Temperature:
Permissible range from 25°C to 75°C
EMC protection:
CE “heavy industrial”
Container:
IP-30 protection.
Technology:
SMD, on one card.

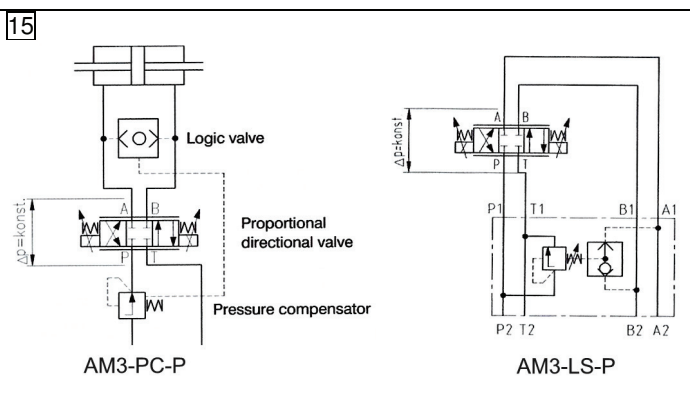

15 PRESSURE COMPENSATOR MODULES.

2-way pressure compensator for meter-in application type AM3-PC-P – see table AM-391.
When using the 2-way pressure compensators in meter-in application, shown in the circuit diagram, a constant pressure difference across the metering edge of the proportional direction valve is held. In this case, the pressure variations due to loading changes, as well as pump pressure changes, are compensated. That means that a pressure change cannot result in flow increase.

3-way pressure compensator type AM3-LS-P (See table AM-390) is able to operate as “load sensing” device, by discharging at T port, at the same pressure of the user, the flow that exceeds the flow rates required by the controlled opening of the proportional 4-way valve.