

Vise Lacer Instructions

X1197E

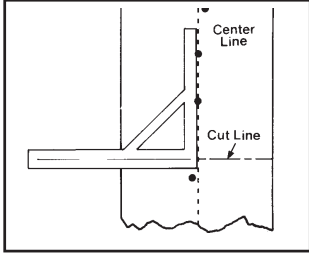

Belt Preparation:



1. Square belt end off centerline.

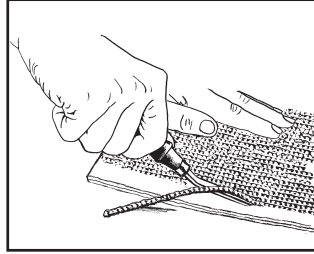

2. If belt has an impression cover, skive back 1" (25mm) from the belt end.

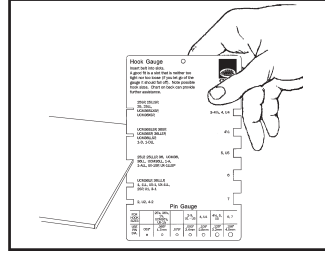

3. Select the proper size hook for your application.

Lacer Operation:

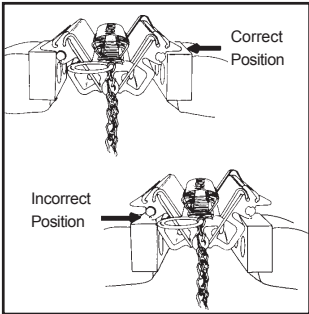

1. Insert lacer in vise.

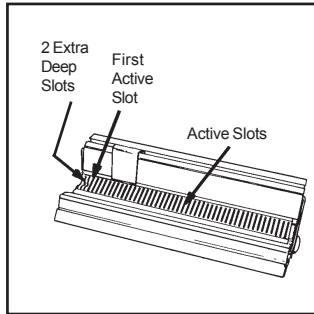

2. Insert hooks into active slots of the hook retainer. Secure with lacer pin.

3. If the lacer is narrower than the vise, position it in the center. If the lacer is wider than the vise, align it with the edge of the vise jaw and complete steps 4-8. Slide the lacer in the vise to the next section to be laced and complete steps 4-8 again.

4. Close vise until lacer jaws are snug against hooks.

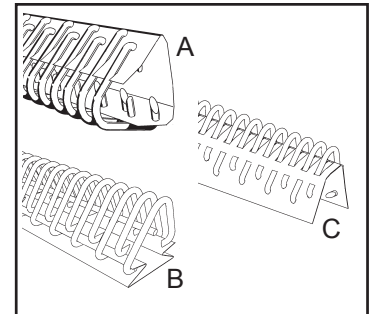

5. If using hooks as shown in A or B, remove carding paper at this time. If using hooks as shown in C, remove carding paper after installing hooks.

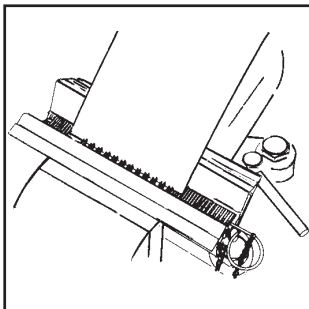

6. Insert belt between hook points with the bottom side of the belt facing the pressure plate. Hold belt flush on the hook retainer.

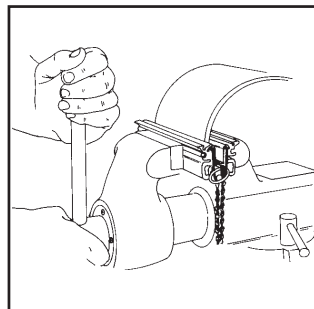

7. With the pressure plate positioned to one side, tightly close vise.

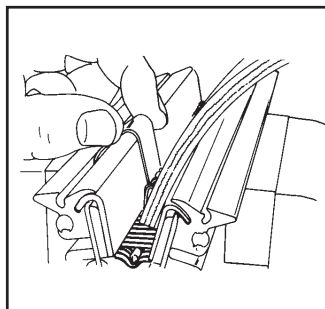

8. Open vise, move pressure plate over 1" (25mm) and close vise tightly again. Repeat until entire splice has been in contact with the pressure plate.

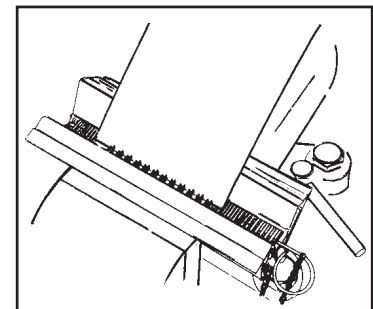

9. Open vise, remove lacer pin and remove belt from lacer.
NOTE: The belt will need to be 'continuous laced' if it is wider than the lacer.

Continuous Lacing:

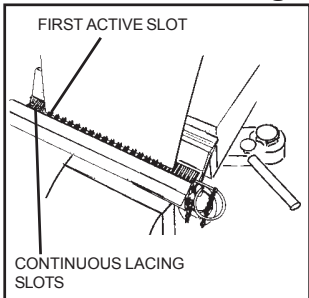

1. Lace the first section using the 'Lacer Operation' instructions listed above.
2. Insert hooks into the hook retainer, starting with the first active slot.
3. Remove paper, if applicable.
4. Insert belt into lacer. Position so the last two laced hooks fit into the extra deep slots located next to the active slots.
5. Continue lacing under normal procedures.

