



# Zungendüsen FT

**NEU**

Verstopfungsunanfällige Flachstrahldüse.

### Vorteile

- Kompakte Bauweise
- Große runde Fließquerschnitte
- Freispülen der Prallfläche bei Verschmutzungen
- Strahlaufbau bereits ab 1 bar
- FT 90 besonders abdriftarm dank Vorzerstäuber

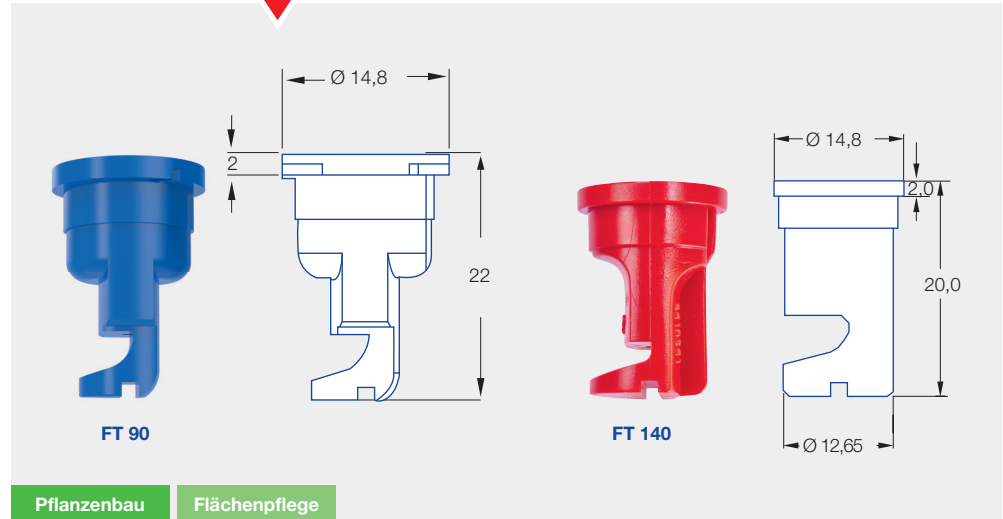

Pflanzenbau

Flächenpflege



**Düsengröße**  
0,5 – 10,0



**Schlüsselweite**  
Ø 12,65 mm



**Spritzwinkel**  
90° 140°

### Anwendungsbereiche



Pflanzenschutzmittel und Wachstumsregulatoren



**Werkstoffe**  
POM, Edelstahl



Rückenspritzen



**Druckbereich**  
- FT 90: 1 – 3 – 6 bar  
- FT 140: 1 – 2 – 3 bar



Dropleg<sup>UL</sup>



**Empfohlene Filter**  
80 M 0,5  
60 M 0,5 – 2,0  
25 M 2,5 – 10,0



Gewächshaus



**Tropfengröße**  
Mittel – fein



Bandspritzung  
FT90

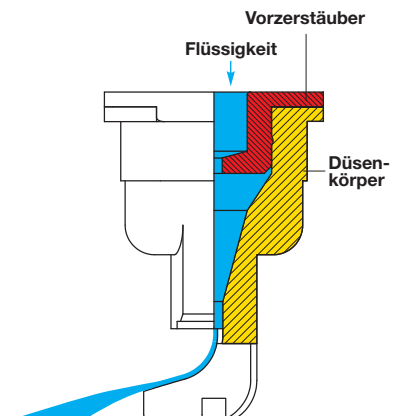

# Spritztable für Zungendüsen FT

 	/min	/ha 						/ha 						
		6	8	10	12	14	16	6	8	10	12	14	16	
		km/h	km/h	km/h	km/h	km/h	km/h	km/h	km/h	km/h	km/h	km/h	km/h	
<b>FT 90-01</b> <b>140-01</b> (80 M)	1	0,23	46	35	28	23	20	17	31	23	18	15	13	12
	2	0,32	64	48	38	32	27	24	43	32	26	21	18	16
	3	0,39	78	59	47	39	33	29	52	39	31	26	22	20
	4	0,45	90	68	54	45	39	34	60	45	36	30	26	23
6	0,55	110	83	66	55	47	41	73	55	44	37	31	28	
<b>FT 90-015</b> <b>140-015</b> (60 M)	1	0,34	68	51	41	34	29	26	45	34	27	23	19	17
	2	0,48	96	72	58	48	41	36	64	48	38	32	27	24
	3	0,59	118	89	71	59	51	44	79	59	47	39	34	30
	4	0,68	136	102	82	68	58	51	91	68	54	45	39	34
6	0,83	166	125	100	83	71	62	111	83	66	55	47	42	
<b>FT 90-02</b> <b>140-02</b> (60 M)	1	0,46	92	69	55	46	39	35	61	46	37	31	26	23
	2	0,65	130	98	78	65	56	49	87	65	52	43	37	33
	3	0,80	160	120	96	80	69	60	107	80	64	53	46	40
	4	0,92	184	138	110	92	79	69	123	92	74	61	53	46
6	1,13	226	170	136	113	97	85	151	113	90	75	65	57	
<b>FT 90-03</b> <b>140-03</b> (60 M)	1	0,69	138	104	83	69	59	52	92	69	55	46	39	35
	2	0,97	194	146	116	97	83	73	129	97	78	65	55	49
	3	1,19	238	179	143	119	102	89	159	119	95	79	68	60
	4	1,37	274	206	164	137	117	103	183	137	110	91	78	69
6	1,68	336	252	202	168	144	126	224	168	134	112	96	84	
<b>FT 90-04</b> <b>140-04</b> (60 M)	1	0,91	182	137	109	91	78	68	121	91	73	61	52	46
	2	1,29	258	194	155	129	111	97	172	129	103	86	74	65
	3	1,58	316	237	190	158	135	119	211	158	126	105	90	79
	4	1,82	364	273	218	182	156	137	243	182	146	121	104	91
6	2,23	446	335	268	223	191	167	297	223	178	149	127	112	
<b>FT 90-05</b> <b>140-05</b> (25 M)	1	1,14	228	171	137	114	98	86	152	114	91	76	65	57
	2	1,61	322	242	193	161	138	121	215	161	129	107	92	81
	3	1,97	394	296	236	197	169	148	263	197	158	131	113	99
	4	2,27	454	341	272	227	195	170	303	227	182	151	130	114
5	2,54	508	381	305	254	218	191	339	254	203	169	145	127	
6	2,79	558	419	335	279	239	209	372	279	223	186	159	140	
<b>FT 140-06</b> (25 M)	1	1,36	272	204	163	136	117	102	181	136	109	91	78	68
	2	1,93	386	290	232	193	165	145	257	193	154	129	110	97
	3	2,36	472	354	283	236	202	177	315	236	189	157	135	118
<b>FT 140-08</b> (25 M)	1	1,82	364	273	218	182	156	137	243	182	146	121	104	91
	2	2,58	516	387	310	258	221	194	344	258	206	172	147	129
	3	3,16	632	474	379	316	271	237	421	316	253	211	181	158
<b>FT 140-10</b> (25 M)	1	2,27	454	341	272	227	195	170	303	227	182	151	130	114
	2	3,22	644	483	386	322	276	242	429	322	258	215	184	161
	3	3,94	788	591	473	394	338	296	525	394	315	263	225	197
<b>FT 140-15</b> (25 M)	1	3,41	682	512	409	341	292	256	455	341	273	227	195	171
	2	4,83	966	725	580	483	414	362	644	483	386	322	276	242
	3	5,91	1182	887	709	591	507	443	788	591	473	394	338	296
<b>FT 140-20</b> (25 M)	1	4,55	910	683	546	455	390	341	607	455	364	303	260	228
	2	6,43	1286	965	772	643	551	482	857	643	514	429	367	322
	3	7,88	1576	1182	946	788	675	591	1051	788	630	525	450	394

- Betriebsdruck an der Düse (gemessen mit Membranventil)
- Die angegebenen Ausbringmengen gelten für Wasser.
- Tabellenwerte vor jeder Spritzsaison durch Auslitern überprüfen.
- Auf gleichmäßige Düseneinstellung achten.

## Bestellbeispiel

Typ	+	Spritzwinkel	+	internationale Düsengröße	+	Werkstoff	=	Bestellnummer
FT 90		90°		01		(POM)	=	FT 90-01 POM
FT 140		140°		01		(POM)	=	FT 140-01 POM