

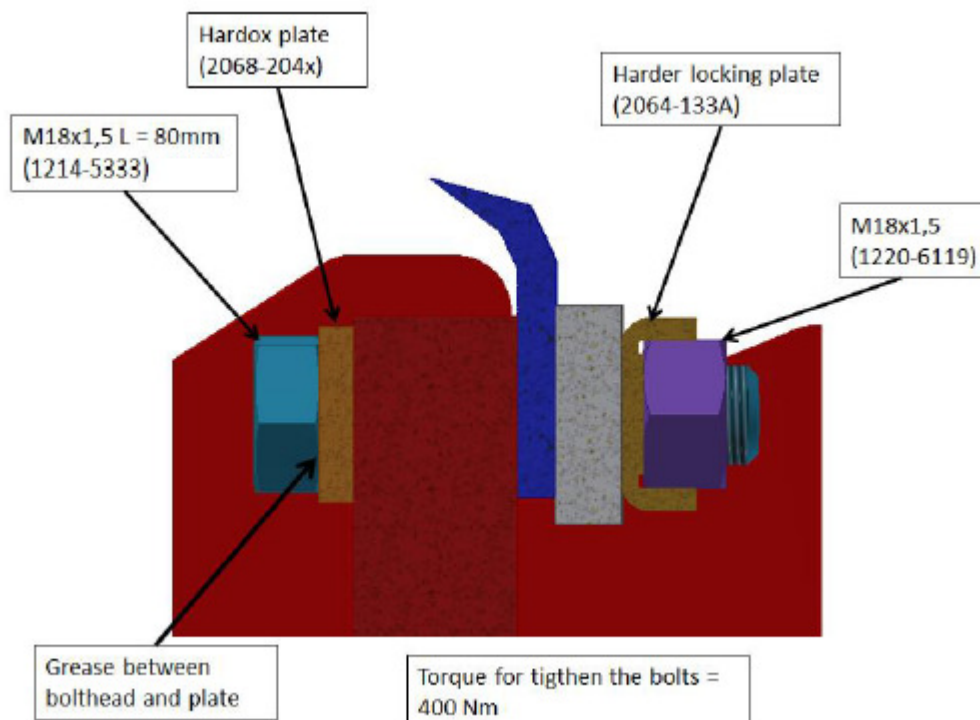

A member of the Kongsild Group

## Changes to FCT Blade Bolts and Plates

New bolts and spacer plates are being introduced on 2015 model FC/FCT foragers, the new part numbers are listed below. The new bolts are 80mm in length and fine threaded and an additional plate has been fitted. The new type bolts should be tightened to a torque of 400Nm.



These parts can be fitted to earlier 960/1060/1360/1460 machines but can only be **fitted as a complete set** to avoid putting the rotor out of balance and causing **severe damage** to the forager.

If not replacing a full set on un-modified pre 2015 machines then 813064-428X bolt kit with 70mm bolt should still be used.

Excerpt from an FCT 1460 parts list showing the new bolts and plate.

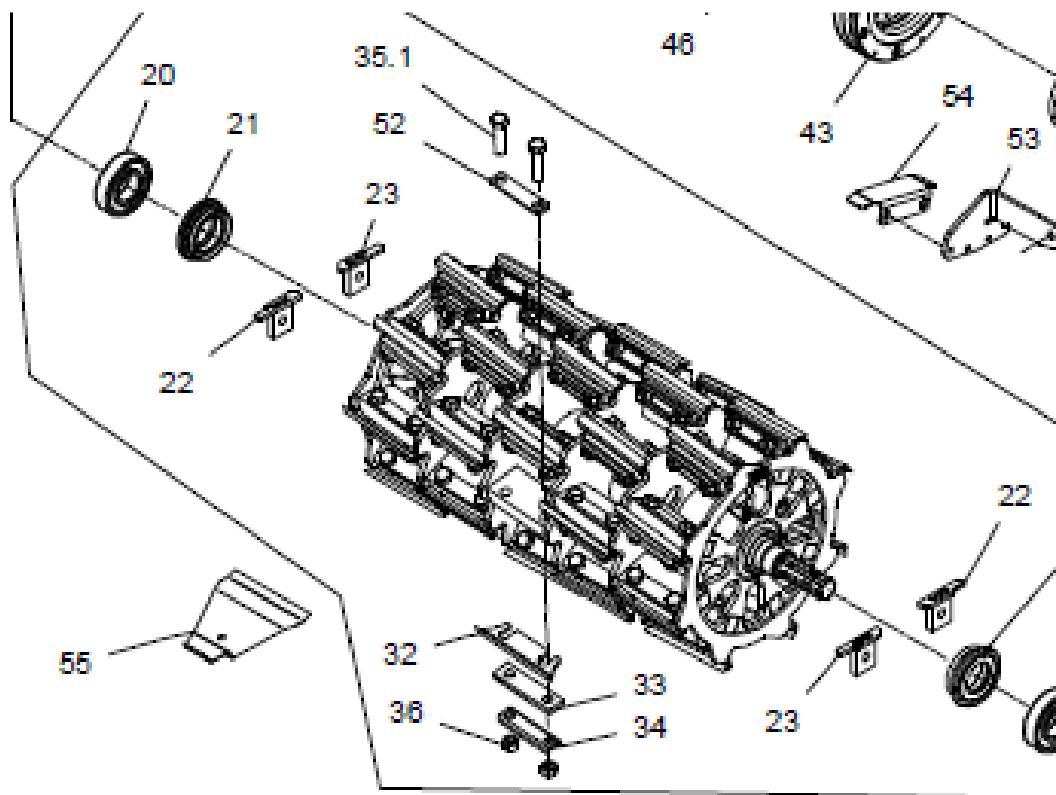

33	812064-134X	Plate	(unchanged)
34	812064-133A	Plate	(new type, harder locking plate)
36	811220-6119	Nut	(new type, fine thread)
35.1	811214-5333	Bolt	(new type, fine thread)
52	812068-204X	Plate	(additional plate)

NB  
14/04/2015