

EMERGENCY TRAILER BRAKE VALVE

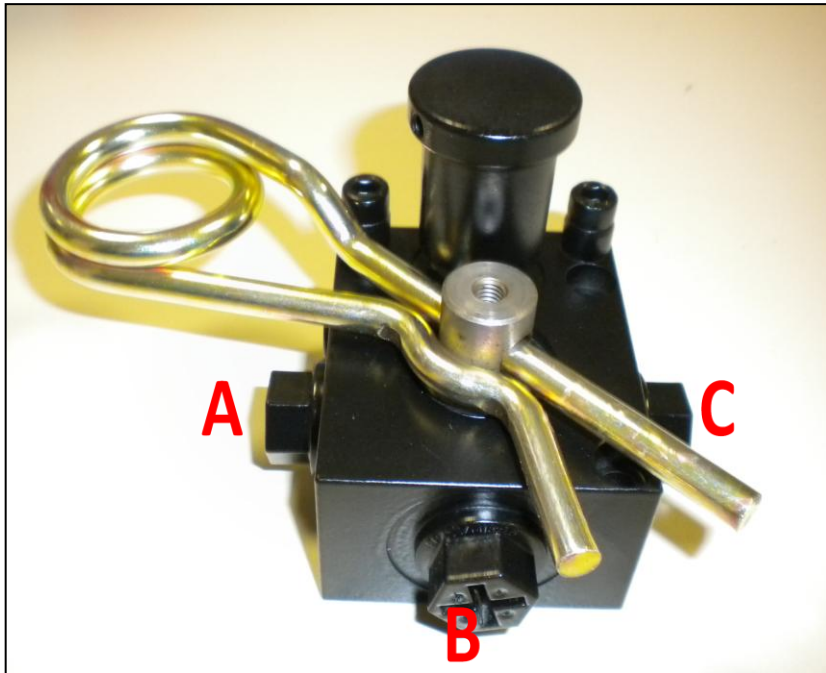

- THE VALVE IS A DEVICE WHICH AUTOMATICALLY APPLIES THE BRAKES ON THE TRAILER IF IT IS ACCIDENTALLY DECOUPLED FROM THE TRACTOR



- PORT "A" : EMERGENCY ACCUMULATOR
- PORT "B" : TRAILER BRAKE
- PORT "C" :

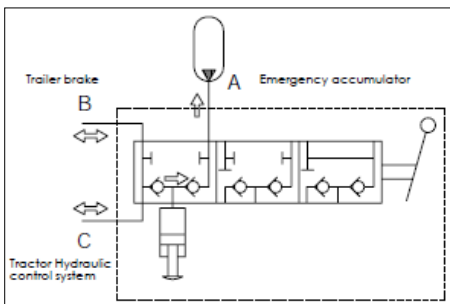

In drive condition the shaft and the pin have to be turned anti clock wise against the lock (accumulator to the brakes is closed). The accumulator recharge while the trailer brakes are actuated.

DRIVE CONDITIONS

Posizione di marcia

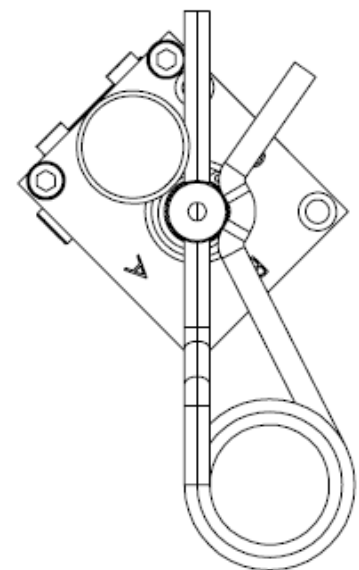

CAUTION !

When the trailer is coupled to the tractor, with the engine running, its necessary to actuate the tractor brake at least 5 seconds to enable the complete recharge of the trailer emergency accumulator

In condizioni di marcia il perno con la spina elastica deve essere ruotato in senso antiorario contro la vite di arresto (accumulatore ai freni chiuso). L'accumulatore si ricarica a durante le frenature del rimorchio.

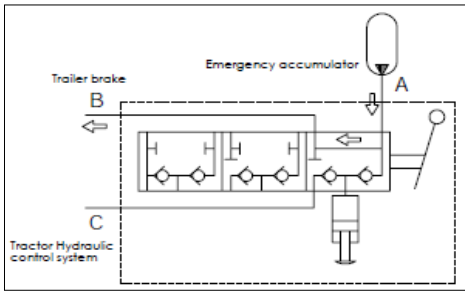

With the shaft rotated and the pin out, this prompts the valve to open the accumulator, pressurizing the brake circuit and bringing the trailer to an emergency stop.

BRAKES ACTUATED
Freni bloccati

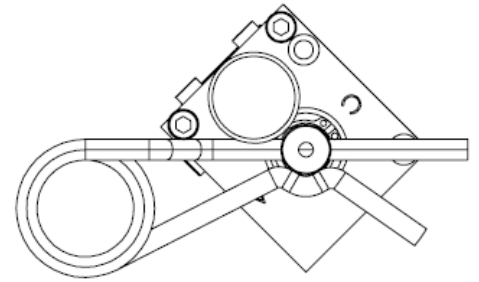

ATTENTION !

This is an emergency brake valve.

IT IS NOT A PARK BRAKE DEVICE !

Il perno ruotato e la spina estratta tramite il cavo permette alla valvola di aprire il circuito dell'accumulatore, pressurizzare i freni ed avere una frenata di emergenza.

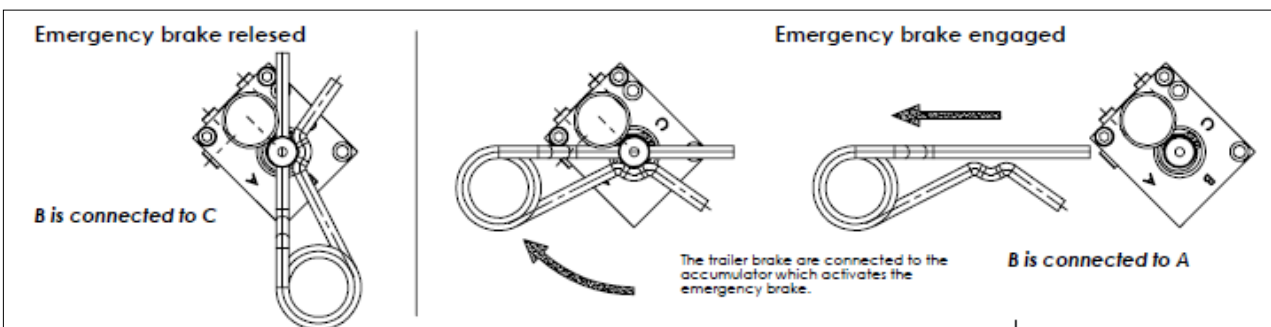
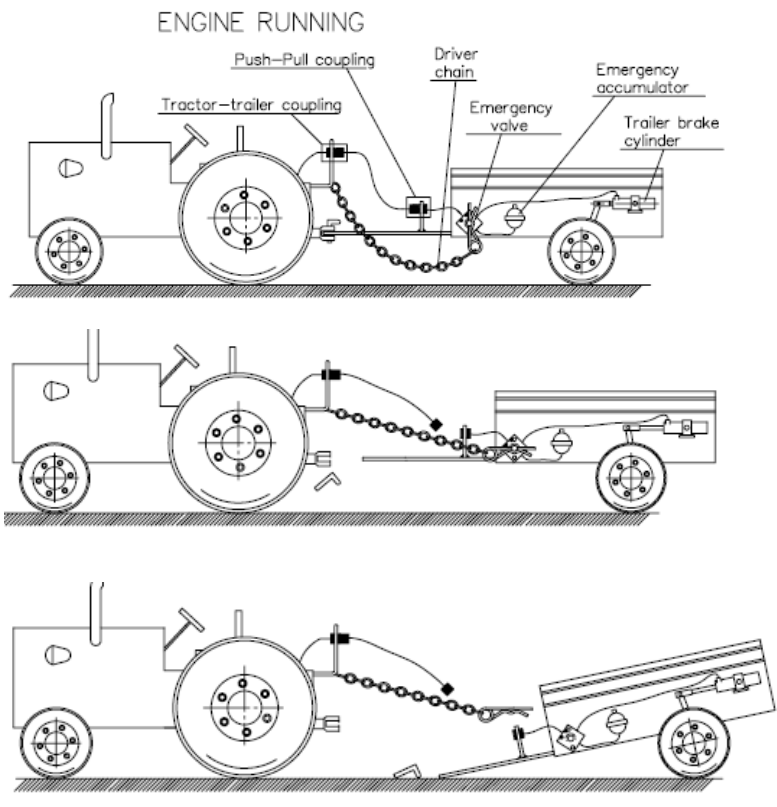

REMOVAL OF THE RESIDUAL PRESSURE Sbloccaggio tubo in pressione

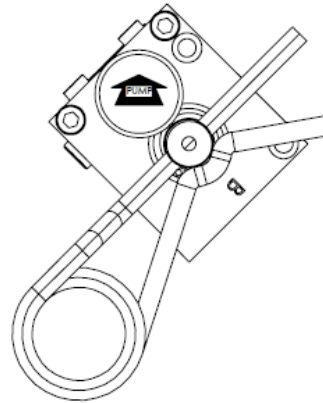
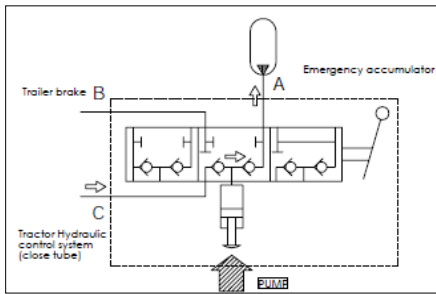

Operating instruction:

Before to connect the quick coupler of the trailer hose to the tractor trailer brake valve it's suggested to remove the residual pressure of the trailer brake hose to permit the connection.

Rotate the shaft into the intermediate position (see picture above) and actuate several time the hand pump to discharge the oil from the hose by pumping the same into the accumulator. This operation enable the easy connection of the quick coupling to the trailer brake valve.

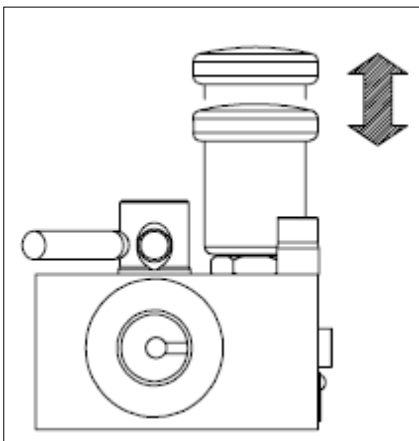

FAQ:

WHAT IS IT THE FUNCTION OF THE DISCHARGE PRESSURE BUTTON?

The function of the "discharge pressure button" is to allow discharging the residual pressure on the "C" line.

Why from the "C" line ?

Because once the trailer has been disconnected from the tractor, left few hours in park position, and the operator would like to reconnect once more the male quick coupling to the trailer brake valve of the tractor, usually there is a residual pressure into the hose (C line) that doesn't allow an easy re-coupling operation.

Why the pressures rise into the line C while the trailer is resting in parking position?

Because when you disconnect the trailer from the tractor the accumulator is at his maximum pressure and after some hours this pressure move to the "C" line through the emergency valve.

Why the emergency valve leak oil from the accumulator to the hose "C"?

Because even if the tolerances between the valve spool and valve body is very tight and due to the manufacturing process, there is not any seal in between the parts and therefore the system is not "zero leakage".

This very little leakage between the spool and the valve body, after some hours, allows the pressure from the accumulator to pressurize the "C" line.

How can I remove the residual pressure from the "C" line?

By using the discharge press button (hand pump) you can move the oil from the "C" line through the check valve 1 and 2 to the accumulator "A", and the residual pressure of the "C" line will drop allowing the operator to re-couple male and female quick connectors, very easily.

A	Emergency accumulator
B	Trailer brakes
C	Tractor hydraulic control system

