

## Assembly instructions VOSSRing<sup>M</sup> in conjunction with universal pre-assembly stud

### 1 Notes

These assembly instructions describe the pre-assembly of the VOSSRing<sup>M</sup> in conjunction with the universal pre-assembly stud in steel or heavy duty steel.

However, to use the VOSSRing<sup>M</sup> the use of specially developed VOSSRing pre-assembly stud is nevertheless recommended. Only in this way can the patented stop function and the shortened 30° final assembly route be used.

Before starting assembly work please consider the general notes in the latest VOSS catalog and check that your assembly instructions are up to date!

These assembly instructions describe the manual mounting options provided in DIN 3859-2.

However, we always recommend assembly using VOSS pre-assembly devices and tools. Here the respective operating instructions must be observed.



For use with steel and stainless steel tubes according to VOSS specification (see introduction assembly instructions).

**Attention!**  
Please note the recommendation on the use of support sleeves for thin-walled steel tubes and soft tubes of non-ferrous metals and support sleeves of material 1.4571 for thin-walled stainless steel tubes.

### 2 Tube preparation

#### 2.1 Minimum dimensions of the straight tube ends must be taken into account for determining the tube lengths.

Series	Tube OD [mm]	H [mm]	L [mm]
L	6/8	31	39
L	10/12	33	42
L	15	36	45
L	18	38	48
L	22/28	42	53
L	35/42	48	60

Series	Tube OD [mm]	H [mm]	L [mm]
S	6/8	35	44
S	10/12	37	47
S	14/16	43	54
S	20	50	63
S	25	54	68
S	30	58	72
S	38	65	82

With machine pre-assembly, the minimum lengths are contained in the respective operating instructions of the pre-assembly devices.

#### 2.2 Saw off tube at a right angle. An angular tolerance of $\pm 1^\circ$ is permissible. Do not use tube cutters or abrasive cutting machines.

#### 2.3 Slightly deburr tube ends inside and outside. Clean tube.

**Attention!**  
Tubes cut crookedly or improperly deburred reduce service life and the tightness of the connection.

#### 2.4 Assembly of VOSS reinforcement sleeves.

- 1a. Lightly coat the outer circumference of the steel sleeve with lubricant (e.g. mineral-oil based hydraulic oil HLP32). Then insert the sleeve into the tube up to the knurled section.
- 1b. Lightly coat the outer circumference of the stainless steel sleeve with assembly paste (e.g. assembly paste MPE). Then insert the sleeve into the tube up to the knurled section.
2. Use a hammer (plastic or hard rubber) to drive in the sleeve totally. In doing so, the knurled section is pressed against the inner wall of the tube and prevents the sleeve from being displaced or falling out.

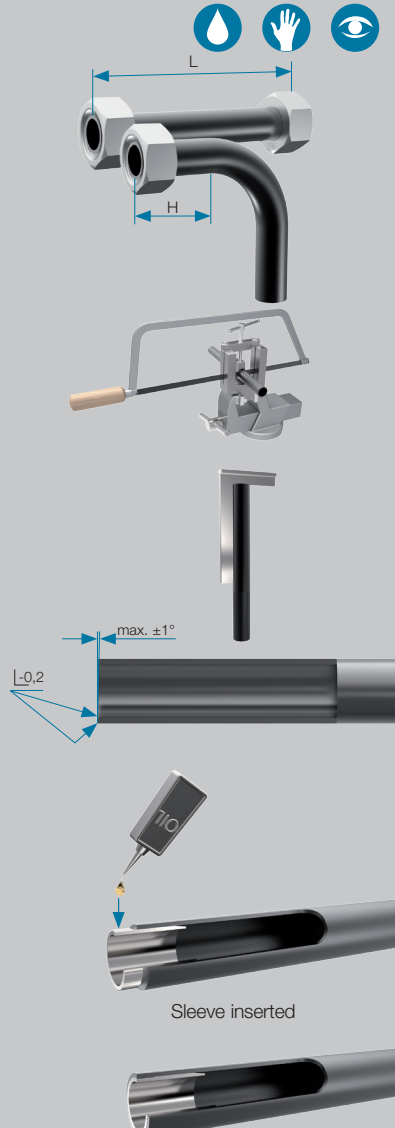

Series	Tube-OD [mm]	Wall thickness [mm]						
		0.5	0.75	1	1.5	2	2.5	3
L	6	•	•					
L	8	•	•					
L	10	•	•					
L	12	•	•	•				
L	15	•	•	•				
L	18	•	•	•	•			
L	22	•	•	•	•	•		
L	28	•	•	•	•	•	•	
L	35	•	•	•	•	•	•	•
L	42	•	•	•	•	•	•	•
S	6	•	•					
S	8	•	•					
S	10	•	•					
S	12	•	•	•				
S	14	•	•	•				
S	16	•	•	•	•			
S	20	•	•	•	•	•		
S	25	•	•	•	•	•	•	
S	30	•	•	•	•	•	•	•
S	38	•	•	•	•	•	•	•

### 3 Assembly preparation

#### 3.1 Lightly lubricate the thread, the cutting ring, the tube end and the taper of the coupling connecting piece easily with lubricant (e.g. using mineral-oil based hydraulic oil HLP32 or, with stainless steel, assembly paste MPE).

#### 3.2 Put the union nut and the VOSSRing<sup>M</sup> on the tube end one after the other. The cutting edges of the VOSSRing<sup>M</sup> point towards the tube end.

**Attention!**  
Make sure that the VOSSRing<sup>M</sup> is in the right position!

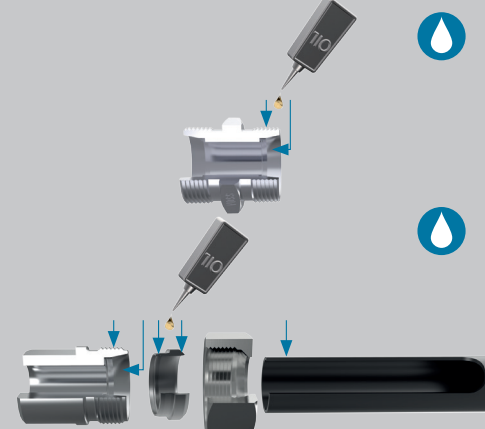

### 4 Pre-assembly

VOSSRing<sup>M</sup> can be pre-assembled directly in the coupling connecting piece or with a hardened universal pre-assembly stud.

Hardened pre-assembly studs in steel are low-wear and enable uniform assembly results. Approximately every 50 pre-assemblies, accuracy to gauge must be checked.

Pre-assembly studs in heavy duty steel have up to 20x longer service life and a "wear inspection". If the usage limit is reached, the front end of the stud breaks off.

**Attention!**  
Universal pre-assembly studs that are not true to gauge or damaged in the cone area must be replaced!

When mounting these directly in the coupling connecting piece, this may be used only once for pre-assembly!

All given assembly instructions must be strictly adhered to! Otherwise the coupling could leak or the tube may be torn out of the coupling!

#### 4.1 Insert the tube end into the 24° taper as far as it will go and press on it. The tube must be held in as far as it can go during the assembly process in order to avoid faulty assembly.

#### 4.2 Tighten the union nut until it is hand tight.

#### 4.3 Tighten the union nut with a wrench to an outer tube.

- to diameter of 18 **1 1/2 turns**
- from 20 mm. **1 1/4 turns**

For assembly into the tube hold the coupling connecting piece in place with a wrench. For compliance with the specified number of turns marking lines are recommended on the union nut and tube.



### 5 Assembly inspection

Loosen the nut and check the shoulder throw-up. The shoulder throw-up should cover approximately 80 % of the cutting-edge front face. With thin-walled tubes and stainless steel tubes the shoulder throw-up has shown to be as markedly less.

In this position, it is still permissible for the cutting ring to turn on the tube. Any dirt must be removed.

**Attention!**  
If not enough tube material has been raised, the procedure must be repeated using more force. The result must be rechecked.

**Note:**  
We recommend the use of the VOSS gauge to check the correct axial position of the cutting ring.

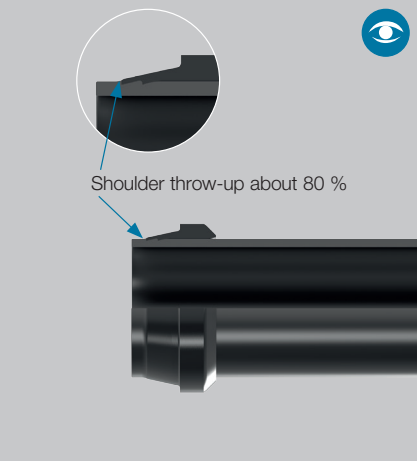

### 6 Final assembly

#### 6.1 Lightly lubricate the thread, the pre-assembled tube end and the taper of the coupling connecting piece easily with lubricant (e.g. using mineral-oil based hydraulic oil HLP32 or, with stainless steel, assembly paste MPE).

#### 6.2 Carefully insert the pre-assembled tube end into the coupling connecting piece. Then tighten the union nut until it is hand tight.

**Attention!**  
If the VOSSRing<sup>M</sup> was pre-assembled in the coupling connecting piece, the same coupling connecting piece used for the direct assembly must be used again for the final assembly.

#### 6.3 Tighten the nut with a wrench until there is a noticeable force increase. As a result, the coupling components are elastically stressed.

Then tighten another 1/4 turn.

**Attention!**  
When tightening up the coupling connecting piece for the final time, always hold it in wrench or clamp it in a vise.

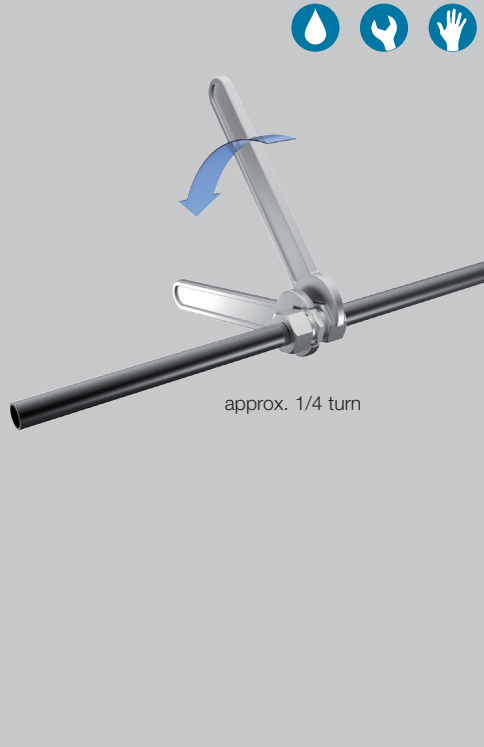

### 7 Repeat assembly

For repeated assembly, the union nut is tightened with the same force as during the initial assembly.

