



Engine model	6404T	Build prefix		Turbo charged
Type de moteur	6404A	Code constructeur	-	Turbo
Modelo de motor	6404A	Código de constructor		Turbo

Cylinder bore Alésage du cylindre Calibre del cilindro
108mm

Piston stroke Course du piston Recorrido del pistón
120mm

Engine capacity Cylindrée Capacidad del motor
6.6 litre

Number of cylinders Nombre de cylindres Número de cilindros
6

Specifications / Spécifications / Especificaciones

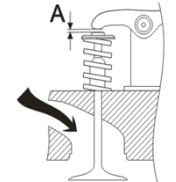
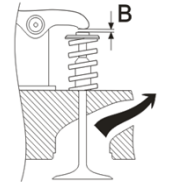
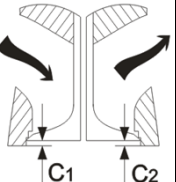
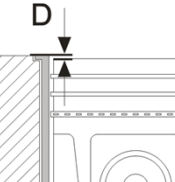
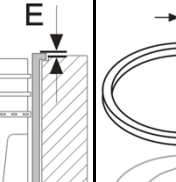
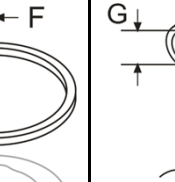
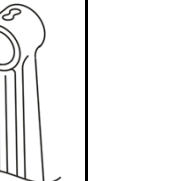
						
A (mm)	B (mm)	C (mm)	D (mm)	E (mm)	F (mm)	G (mm)
0.46	0.71	1 0.76 2 0.76	0.0 - 0.37	0.03 - 0.10	1 2 3	38.13 - 38.15

Torque specifications / Spécifications de couple / Especificación de torsión

		Nm	lbft	Degrees
Cylinder head bolts Vis de culasse Pernos culata	1st stage 1ère étape Primer paso	136	100	
	2nd stage 2ème étape Segundo paso	163	120	
	Run for 0.5 hours / Faire fonctionner 0.5 heures / Ejecutar durante 0.5 horas			
	3rd stage 3ème étape Tercer paso	183	135	
Main bearing bolts Vis, chaise de palier-vilebrequin Pernos rodamiento principal		203	150	
Connecting rod bolts Vis de bielles Pernos de biela		136	100	
Flywheel bolts Boulons de roue Pernos volante		115	85	