

DESIGNATION C3A TWO SPEED GEAR

CODE N° 5367.111.023

POS.	DRG. N.	PIEC	DESCRIPTION
1	0.104.7500.00	2	SHIM KIT 20.3x32.0
2	0.124.7101.00	1	PLATE "COMER"
3	0.702.7500.00	3	SHIM KIT 80.3x89.7
4	1366.019.041	1	LEVER
5	1367.001.002	1	HOUSING
6	1367.003.042	1	SHAFT 1"3/4 Z20
7	1367.004.042	1	MIDDLE SHAFT 56x65
8	1367.008.026	1	GEAR Z37 M4
9	1367.012.026	1	GEAR Z47 M4
10	1367.014.025	1	COVER
11	1367.015.061	1	COVER
12	1367.016.061	4	THRUST WASHER
13	1367.020.098	1	FORK
14	1367.024.098	1	INNER LEVER
15	1367.028.061	2	LUBRICATING SHEET
16	1367.030.076	2	SPACER
17	1367.032.099	2	BUSHING
18	1367.033.026	1	GEAR Z37 M4
19	1367.034.026	1	GEAR Z26 M4
20	1367.035.042	1	SLIDE GEAR
21	1367.036.041	1	GEAR SELECTOR ROD
22	1367.038.042	1	GEAR Z41 M4
23	1367.039.000	2	SPRING D7X37.3
24	1367.045.042	1	GEAR Z32 M4
25	1367.099.042	1	DUEL OUTPUT SHAFT1"3/4 Z20
26	8.0.9.00888	3	TAPERED ROLLER BEARING 30210
27	8.0.9.01782	3	TAPERED ROLLER BEARING 32210
28	8.1.1.00041	8	HBB BOLT M8X22 UNI5739 8,8
29	8.1.1.00209	6	HBB BOLT M10x16 UNI5739 8.8
30	8.3.0.01353	1	ALUMINUM WASHER 17x22x1.5
31	8.4.5.01025	1	SPRING PIN 8x36 DIN1481
32	8.5.1.01163	2	SNAP RING FOR SHAFT D65 UNI7435
33	8.5.1.01211	4	SNAP RING FOR SHAFT D20 H=1.75 UNI7436
34	8.5.2.01886	5	SNAP RING FOR HOLE D90 H=4 UNI7438
35	8.5.9.02598	2	BALL D7 mm.
36	8.6.4.00273	1	LEV. WARNING LIGHT 3/8"GAS
37	8.6.5.00006	1	PLUG EXTERNAL 3/8"GAS
38	8.6.7.01833	1	OIL BREATHER PLUG 1/2"GAS
39	8.7.0.01054	2	CAP 90x10
40	8.7.1.01107	3	OIL SEAL 50x90x10 TYPE AS DIN3760
41	8.7.3.02599	1	DUST LIP 50x80x8
42	8.7.6.01966	3	O-RING OR-2068
	A.367.005	1	
251	1367.017.042	1	JOINT MF Z20 D22 N32 CH.6
252	8.5.2.02422	1	SNAP RING 22 UNI7437

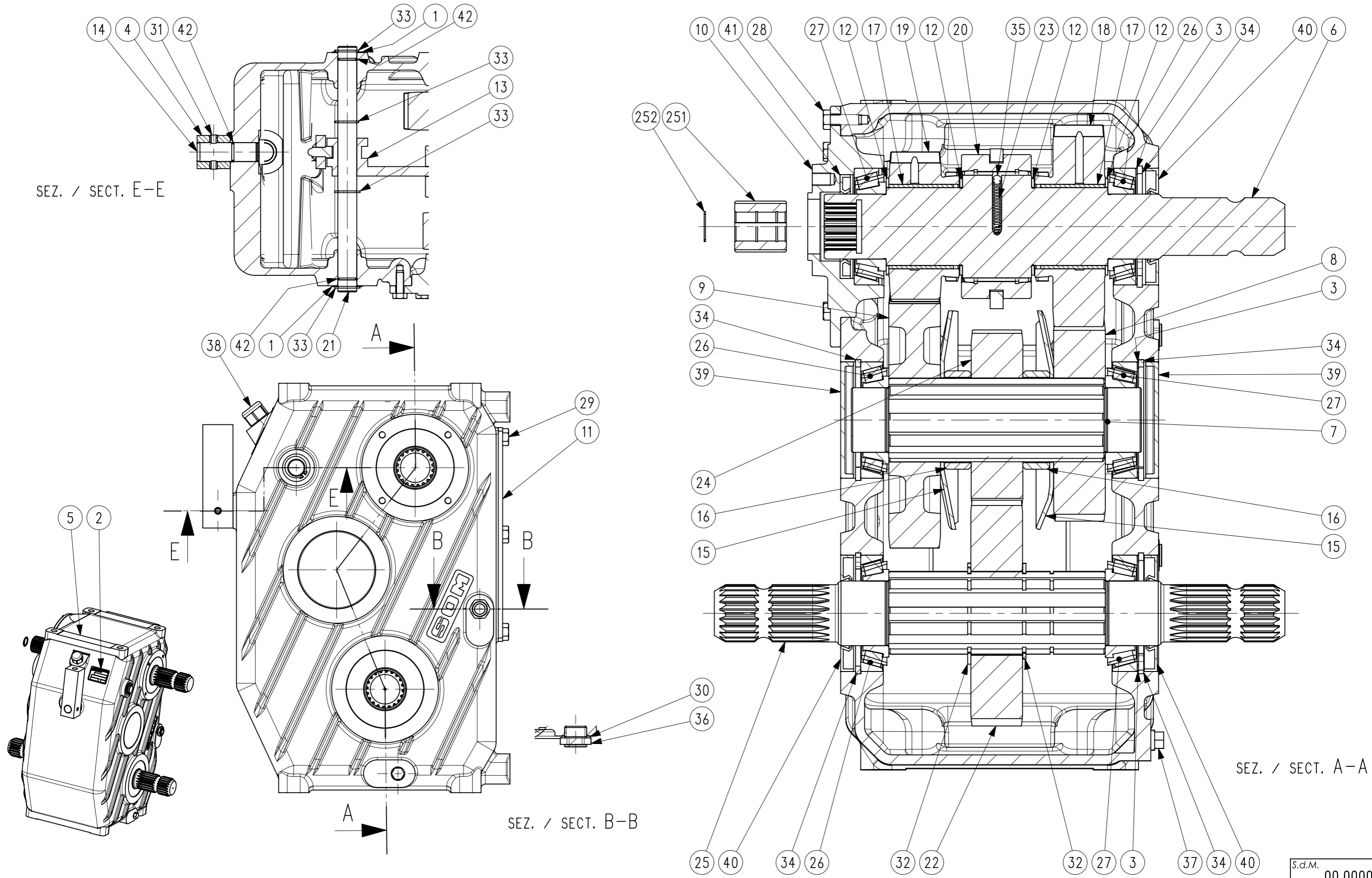

Code
Codice
Bestell-Nr.
Code

5367.111.023

Designation
Denominazione
Bezeichnung
Reference

C-3 A

Company
Ditta
Firma
Etablissement

Ref.
Rif.
Betr.
Ref.

Date
Data
Datum
Date

09-04-2021

s.d.M.
00.00000

COMER INDUSTRIES reserves the right to make any change to this product without prior public acknowledgement - COMER INDUSTRIES si riserva di apportare al proprio prodotto tutte quelle modifiche che si rendessero necessarie senza alcun preavviso
COMER INDUSTRIES behält sich das recht vor das eigene Produkt ohne vorherige Benachrichtigung zu verändern beziehungsweise zu modifizieren - COMER INDUSTRIES se réserve la faculté de modifier les données techniques du produit sans préavis

COMER INDUSTRIES S.p.A. 42046 Villanova di Reggiolo (R.E.) Italia Tel. 0522\974111 (9 Linee) Fax 0522\973249

