



Engine model Type de moteur Modelo de motor	4239T	Build prefix Code constructeur Código de constructor	-	Turbo charged Turbo Turbo
---	-------	--	---	---------------------------------



Cylinder bore Alésage du cylindre Calibre del cilindro
106.5mm

Piston stroke Course du piston Recorrido del pistón
110mm

Engine capacity Cylindrée Capacidad del motor
3.9 litre

Number of cylinders Nombre de cylindres Número de cilindros
4

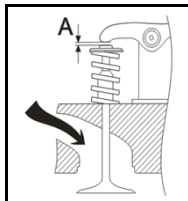
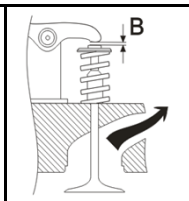
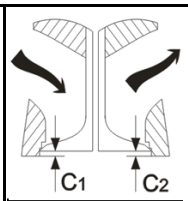
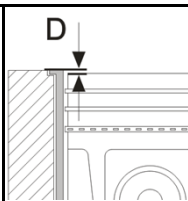
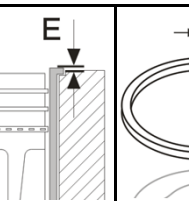
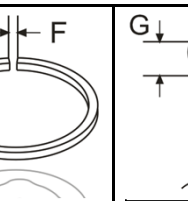
Specifications / Spécifications / Especificaciones

						
A (mm)	B (mm)	C (mm)	D (mm)	E (mm)	F (mm)	G (mm)
0.35	0.45	1 0.61 - 1.11 2 1.22 - 1.72	0.03 - 0.10	0.03 - 0.10	1 2 3	41.30 - 41.33

Torque specifications / Spécifications de couple / Especificación de torsión

		Nm	lbft	Degrees
Cylinder head bolts Vis de culasse Pernos culata Main Bearing bolts Vis, chaise de palier-vilebrequin Pernos rodamiento principal	1st stage 1ère étape Primer paso	100	74	
	2nd stage 2ème étape Segundo paso	150	111	
	Wait 5 minutes / Attendre 5 minutes / Espere 5 minutos			
	3rd stage 3ème étape Tercer paso	150	111	
	4th stage 4ème étape Cuarto paso			60
Main bearing bolts Vis, chaise de palier-vilebrequin Pernos rodamiento principal		120	89	
Connecting rod bolts Vis de bielles Pernos de biela		(a) 75 (b) 95	(a) 55 (b) 70	
Flywheel bolts Boulons de roue Pernos volante		160	118	

Remarks

- (a) Black bolts
- (b) Silver bolts

Remarques

- (a) Boulons noirs
- (b) Boulons argentés

Comentarios

- (a) Pernos negros
- (b) Pernos plateados